

Item No.

Built To Anets Standards, Priced For Today's Market, The SilverLine Fryer From Anets

Anets provides the best value in frying with the new SLG40 gas fryer. The improved design provides an affordable fryer that keeps up with load after load of production. The heating system has been engineered for maximum efficiency and cleanability. Using 2 burner tubes equipped with computer designed radiants, this fryer requires only 90,000 BTU (26 kW) (95 Mj) input to achieve maximum cooking capacity. The unique shape of the tubes allows easy access to all areas of the frypot. Center mounted snap action thermostat responds quickly to fry loads. The Anets SLG40 is built to perform, easy to clean, and priced to purchase today.

STANDARD FEATURES

- Stainless steel front, door and trim are standard features
- 90,000 BTUH (26 kW) (95 Mj) from only two tubes, easiest model on the market to clean
- Computer designed radiant enable the burners to efficiently reach 45,000 BTUH (13 kW) (47 Mj) per burner tube
- The unique tapered elliptical tubes provide 14% more heat transfer area than competitive models (see **Design Features** on back)
- Outstanding serviceability, all components easily accessible and replaceable from the front
- Stainless steel basket hanger lifts off for easy cleaning
- Food particles fall below burner tubes into cold zone to prolong shortening life
- Large 1-1/4" (3.2 cm) ball-type full port drain valve prevents clogging



ANETS
SilverLINE™



ANETS'

ANETS INC PO BOX 501, CONCORD, NH 03302-0501
509 ROUTE 3A, BOW, NH 03304 TEL: 603-225-6684, FAX:603-225-8497
L10-507 R5 www.anets.com

We reserve the right to change specifications without notice and without incurring any
Obligation for equipment previously or subsequently sold.

Anets SilverLine 14 Gas Fryer

Model SLG40

SPECIFICATIONS

- Model SLG40, Stainless steel frypot
- Certification CE, CSA, NSF
- Gas Input 90,000, BTU/hr. (26 kW) (95 MJ)
- Gas Pressure NG 3.5 WC (8.7 mbar) (0.87 kPa)
LP 10 WC (25 mbar) (2.5 kPa)
- Gas Connection ½" NPT (1.2 cm) (12.7 mm)
- Electrical Requirements None
- Thermostat Snap action millivolt control
- Temperature Range 175 -375 F, (79 -190 C)
Safety control turns off gas supply at 428 F (220 C)
- Hi-Limit 100% gas shut off valve
- Safety Pilot Cast iron, atmospheric
- Burners Stainless steel
- Frypot Door, stainless steel Backsplash,
stainless steel Basket Hanger, stainless steel
- Cabinet steel
- Shortening Capacity 40-50 lbs (18- 23 kg)
- Frying Area 14 x 14.5 (36cm x 37cm)
- Shipping Weight 145 lbs.(66 kg)
- Warranty 1 year parts and labor

STANDARD ACCESSORIES

- 2 Twin nickel plated baskets
- Rack type basket support
- 6" (15.2 cm) Adjustable legs
- Drain pipe extension
- Flue extension/Diverter

OPTIONS AND ACCESSORIES

- Single or triple baskets
- Casters

DESIGN FEATURES

Two Tubes

- Easier to clean
- Optimum access to cold zone

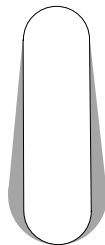
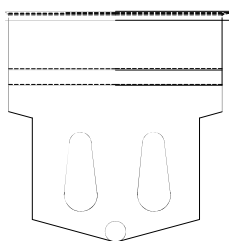

OTHERS

Tapered Elliptical Shape

- 14% more surface area for heat transfer
- Food particles cannot accumulate on top of tubes

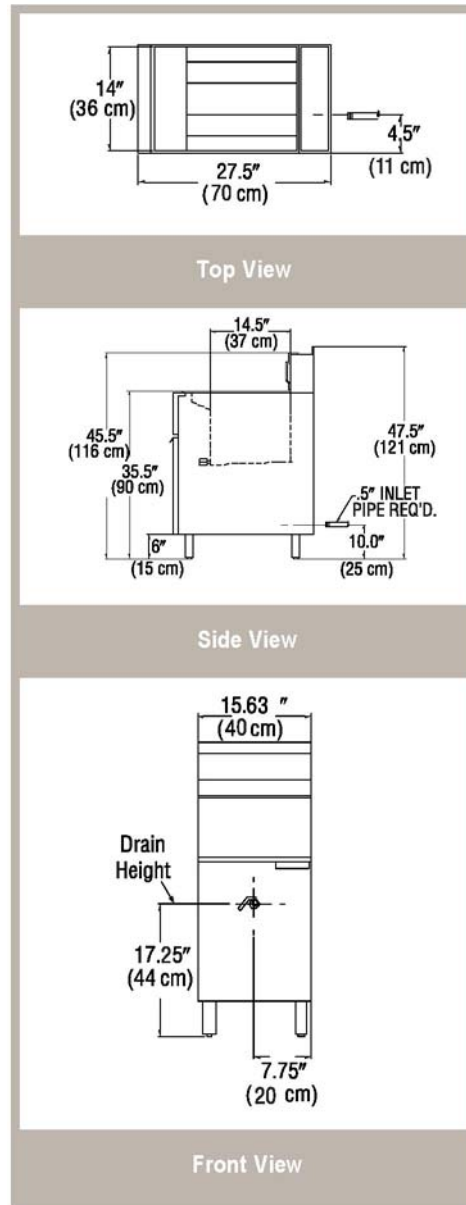

Specifications subject to change without notice.



ANETS INC PO BOX 501, CONCORD, NH 03302-0501
509 ROUTE 3A, BOW, NH 03304 TEL: 603-225-6684, FAX: 603-225-8497
L10-507 R5 www.anets.com

We reserve the right to change specifications without notice and without incurring any obligation for equipment previously or subsequently sold.