

IFSCO

ISLAND FREEZERS

Self Contained Island Freezer

Standard features

- Self Contained
- Wire Floor Trays & Wire Dividers
- Automatic Defrost
- Triple Glazed Panoramic Side Walls
- Triple Glazed Front & Rear Glasses
- Wheels
- Thermostat Electronic Control
- Wellington ERC2 Electronic Fan Motor

Dimensions

Model	IFSCO-5	IFSCO-7
Length (inches)	59"	79"
Width (inches)	43"	43"
Power	220V 60HZ	220V 60HZ
Amperage	25A	32A

Technical Drawings

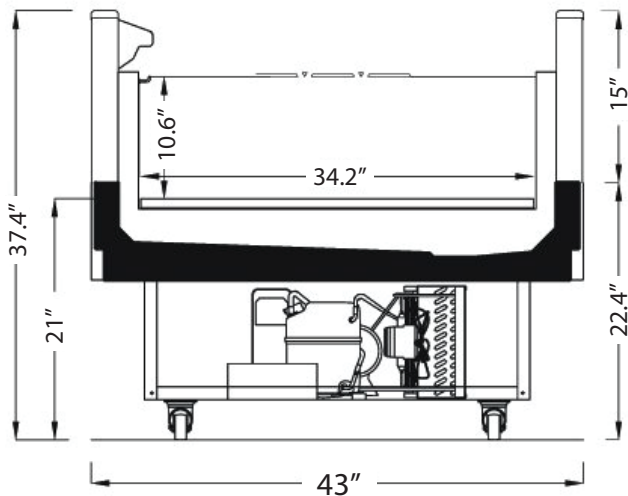

* Customizable options available; * Multiple shelves available; * All measurements are approximates; * Specifications are subject to change without notice; * All equipment are designed to operate in a controlled environment below 75°F (+24°C) temperature and HR 55% relative humidity;

