

ARBF

Wooden Case, Self Contained

GELATO ICE CREAM FREEZER



ARBF4

Standard Features

- Cherry finish wooden case
- Silver aluminium trimming
- Interior LED lighting
- Curved, high tempered front glass
- Stainless steel containers (14 or 28) included, standard size: 14"L x 6.5"D x 4.75"H
- Stainless steel worktop
- Front glass panels opened with telescopic lifts
- Defogger (front glass)
- Illuminated display area
- Night curtain
- Adjustable legs
- Compressor (built in)
- Dynamic cooling
- Ecological polyurethane foam insulation
- Electronic programmable thermostat
- Auto defrost
- Automatic condenser evaporation

Technical Drawing

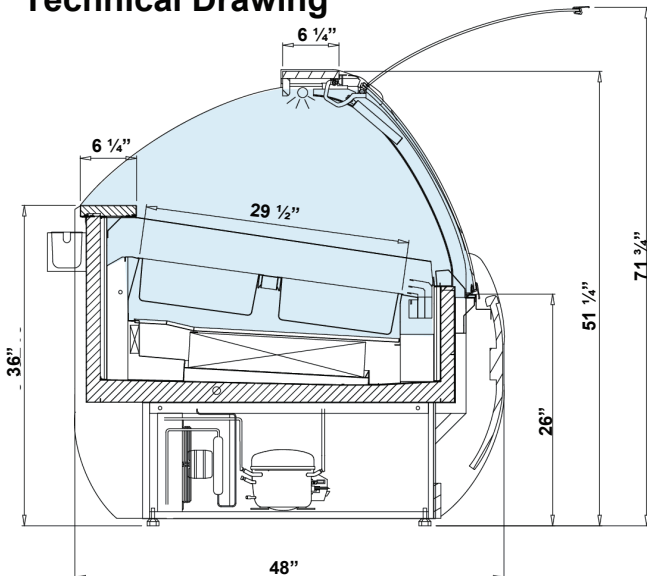

***All equipment designed to operate in controlled environment below 75°F (+24°C) temperature and HR 55% relative humidity.

Options

- Variety of wood finish
- Internal frame painted silver or gold
- Remote compressor

Wood veneer

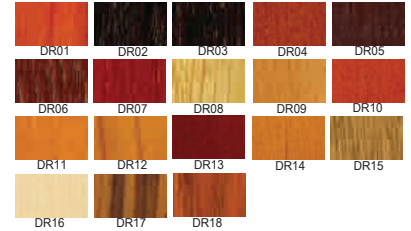

Aluminum profiles colors



Dimensions

Model	Containers	Dimension W x D x H	Weight (lbs/kg)
ARBF4	14	54 1/2" x 48" x 51 1/4"	661 / 300
ARBF8	28	103 1/2" x 48" x 51 1/4"	1,146 / 520

Voltage

- ARBF4: 115V / 1ph / 60 Hz / 15A, max. fuse: 20A
- ARBF8: 2 X 115V / 1ph / 60 Hz / 15A, max. fuse: 20A

* Specifications are subject to change without notice.

**All measurements are approximates.