



## INSTALLATION AND OPERATING INSTRUCTIONS

# Heavy Duty Hot Plates

**MODELS:** HHP-212i / HHP-424i / HHP-636i / HHP-848i  
HHPS-212i / HHPS-424i / HHPS-636i / HHPS-848i

### IMPORTANT FOR FUTURE REFERENCE

Please complete this information and retain this manual for the life of the equipment. For Warranty Service and/or Parts, this information is required.

\_\_\_\_\_   
Model Number

\_\_\_\_\_   
Serial Number

\_\_\_\_\_   
Date Purchased



**FOR YOUR SAFETY:** Do not store or use gasoline or other flammable vapors or liquids in the vicinity of this or any other appliance.



**WARNING:** Improper installation, adjustment, alteration, service or maintenance can cause property damage, injury or death. Read the installation, operating and maintenance instructions thoroughly before installing, or servicing this equipment.



**WARNING:** Instructions must be posted in a prominent location. All safety precautions must be taken in the event the user smells gas. Safety information can be obtained from your local gas supplier.



P/N: 8835505 09/24

### APW WYOTT Foodservice

DALLAS:  
1307 N. Watters Rd #180 • Allen, TX • 75013  
Local: (972) 908-6100  
Toll Free: (800) 431-2745  
Parts/Service Fax: (214) 565-0976

CHEYENNE:  
1938 Wyott Dr • Cheyenne, WY • 82007  
Local: (307) 634-5801  
Toll Free: (800) 752-0863  
Parts/Service Fax: (214) 565-0976

[www.apwwyott.com](http://www.apwwyott.com)

# TABLE OF CONTENTS

<u>SECTION</u>	<u>ITEM</u>	<u>PAGE</u>
1	Safety Precautions.....	2
2	General Installation Instructions.....	4
3	Specifications.....	5
4	Lighting Instructions.....	6
5	Maintenance.....	7
6	Conversion.....	8
7	Replacement Parts Lists & Exploded Views.....	10
8	Warranty.....	12

## LOCATION OF DATA PLATE

The data plate for the gas open burner range is located on the right side panel.

## IMMEDIATELY INSPECT FOR SHIPPING DAMAGE

All containers should be examined for damage before and during unloading. The freight carrier has assumed responsibility for its safe transit and delivery. If equipment is received damaged, either apparent or concealed, a claim must be made with the delivering carrier.

- A) Apparent damage or loss must be noted on the freight bill at the time of delivery. It must then be signed by the carrier representative (Driver). If this is not done, the carrier may refuse the claim. The carrier can supply the necessary forms.
- B) Concealed damage or loss if not apparent until after equipment is uncrated, a request for inspection must be made to the carrier within 15 days. The carrier should arrange an inspection. Be certain to hold all contents and packaging material.

Installation and start-up should be performed by a qualified installer who thoroughly read, understands and follows these instructions.

If you have questions concerning the installation, operation, maintenance or service of this product, write Technical Service Department Bakers Pride, 1307 N Watters Rd # 180, Allen, TX 75013.

## 1. SAFETY PRECAUTIONS

Before installing and operating this equipment be sure everyone involved in its operation is fully trained and is aware of all precautions. Accidents and problems can result by a failure to follow fundamental rules and precautions.

Shut off gas flow through the appliance before cleaning or servicing unit.

The following words and symbols, found in this manual, alert you to hazards to the operator, service personnel or the equipment. The words are defined as follows.



**DANGER:** This symbol warns of imminent hazard which will result in serious injury or death.



**WARNING:** This symbol refers to a potential hazard or unsafe practice, which could result in serious injury or death.



**CAUTION:** This symbol refers to a potential hazard or unsafe practice, which may result in minor or moderate injury or product or property damage.



**NOTICE:** This symbol refers to information that needs special attention or must be fully understood even though not dangerous.



## GENERAL INFORMATION

### THIS MANUAL SHOULD BE RETAINED FOR FUTURE REFERENCE



**CAUTION:** These models are designed, built, and sold for commercial use. If these models are positioned so the general public can use the equipment make sure that cautions, warnings, and operating instructions are clearly posted near each unit so that anyone using the equipment will use it correctly and not injure themselves or harm the equipment.



**WARNING:** A factory authorized agent should handle all maintenance and repair. Before doing any maintenance or repair, contact APW Wyott.



**WARNING:** Improper installation, adjustment, alteration, service or maintenance can cause property damage, injury or death. Read installation, operating and maintenance instructions thoroughly before installing or servicing this equipment.



**WARNING:** For your safety do not store or use gasoline or other flammable vapors or liquids in the vicinity of this or any other appliance. Keep the area free and clear of combustibles. (See ANZI Z83.14B, 1991)



**NOTICE:** Local codes regarding installation vary greatly from one area to another. The National Fire Protection Association, Inc., states in its NFPA96 latest edition that local codes are "Authority Having Jurisdiction" when it comes to requirement for installation of equipment. Therefore, installation should comply with all local codes.



**NOTICE:** This product is intended for commercial use only. Not for household use.



**NOTICE:** Instructions to be followed if anyone smells gas should be posted in a prominent place. These may be obtained from the gas supplier.



**WARNING:** Do not turn on gas valves without lighting pilot. A build up of gas and possible explosion could occur.



## GAS PRESSURE

The appliance and its individual shutoff valve (to be supplied by user) must be disconnected from the gas supply piping system during any pressure testing of that system at test pressures in excess of ½ psi (3.45 kPa). *NOTE: Gas shutoff valve is supplied on CE models.*

The appliance must be isolated from the gas supply piping system by closing its individual manual shut-off valve during any pressure testing of the gas supply piping system at test pressures equal to or less than ½psi (3.45 kPa).

Congratulations on your purchase of Bakers Pride commercial cooking equipment. Bakers Pride takes honor in designing the highest quality products. When used as intended and with proper care and maintenance, you will experience years of reliable operation from this equipment. To ensure best results, it is important that you read and follow the instructions in this manual carefully.

The countertop hot plate, models BPHHP-212i, BPHHP-424i, BPHHP-636i, BPHHP-848i, BPHHPS-212i, BPHHPS-424i, BPHHPS-636i and BPHHPS-848i provide countertop heating and cooking capabilities. These units incorporate 2, 4, 6 or 8 burners for fast, even cooking and heating. Refer to data plate for BTU/hr Rate.

## 2. GENERAL INSTALLATION INSTRUCTIONS

Ensure gas supply and gas type shown on unit data plate match. (Data plate is located on the right side panel of unit).

Unit installation must conform to the National Fuel Gas Code, ANSI Z223.1/NFPA 54, the National Gas Installation Code, CSA B149.1, or the Propane Installation Code, CSA B149.2 as applicable and in accordance with local codes.

Screw legs into the permanently fastened nuts on the four corners of the unit and tighten by hand. Level the unit by turning the adjustment screw at the bottom of each leg. Do not slide unit with legs mounted, lift if necessary to move unit.

Pipe gas supply to unit. The gas supply (service) line must be the same size or greater than the inlet line of the appliance.

Pipe threading compound must be resistant to the action of liquefied petroleum gases.

These units are suitable for installation on non-combustible surfaces.

Unit must have adequate clearances for servicing. (Sides = 0", Rear = 0", Floor = 4")

Commercial cooking equipment must have a pressure regulator on the incoming service line for safe and efficient operation, since service pressures may fluctuate on local demand. A pressure regulator is packed inside every Bakers Pride appliance.

**Failure to install the pressure regulator will void the appliance warranty.**

Prior to connecting the regulator, check the incoming line pressure, as these regulators can only withstand a maximum pressure of ½" psi (14" WC). If the line pressure is beyond this limit, a step down regulator will be required.



**Warning: DO NOT use an open flame to check for leaks. Check all gas piping for leaks with a soap and water solution before operating unit.**



### 3. DIMENSIONS AND SPECIFICATIONS

MODEL	WIDTH (A)	DEPTH (B)	HEIGHT (C)	LEG SPACING (D)	LEG SPACING (E)	REGULATOR SPACING (F)
HHP-212i	12"	31"	14"	8-1/2"	23-1/2"	4"
HHP-424i	24"	31"	14"	20-3/4"	23-1/2"	4"
HHP-636i	36"	31"	14"	32-3/4"	23-1/2"	4"
HHP-848i	48"	31"	14"	44-3/4"	23-1/2"	4"
HHPS-212i	12"	31"	14" FR / 17" RR	8-1/2"	23-1/2"	4"
HHPS-424i	24"	31"	14" FR / 17" RR	20-3/4"	23-1/2"	4"
HHPS-636i	36"	31"	14" FR / 17" RR	32-3/4"	23-1/2"	4"
HHPS-848i	48"	31"	14" FR / 17" RR	44-3/4"	23-1/2"	4"

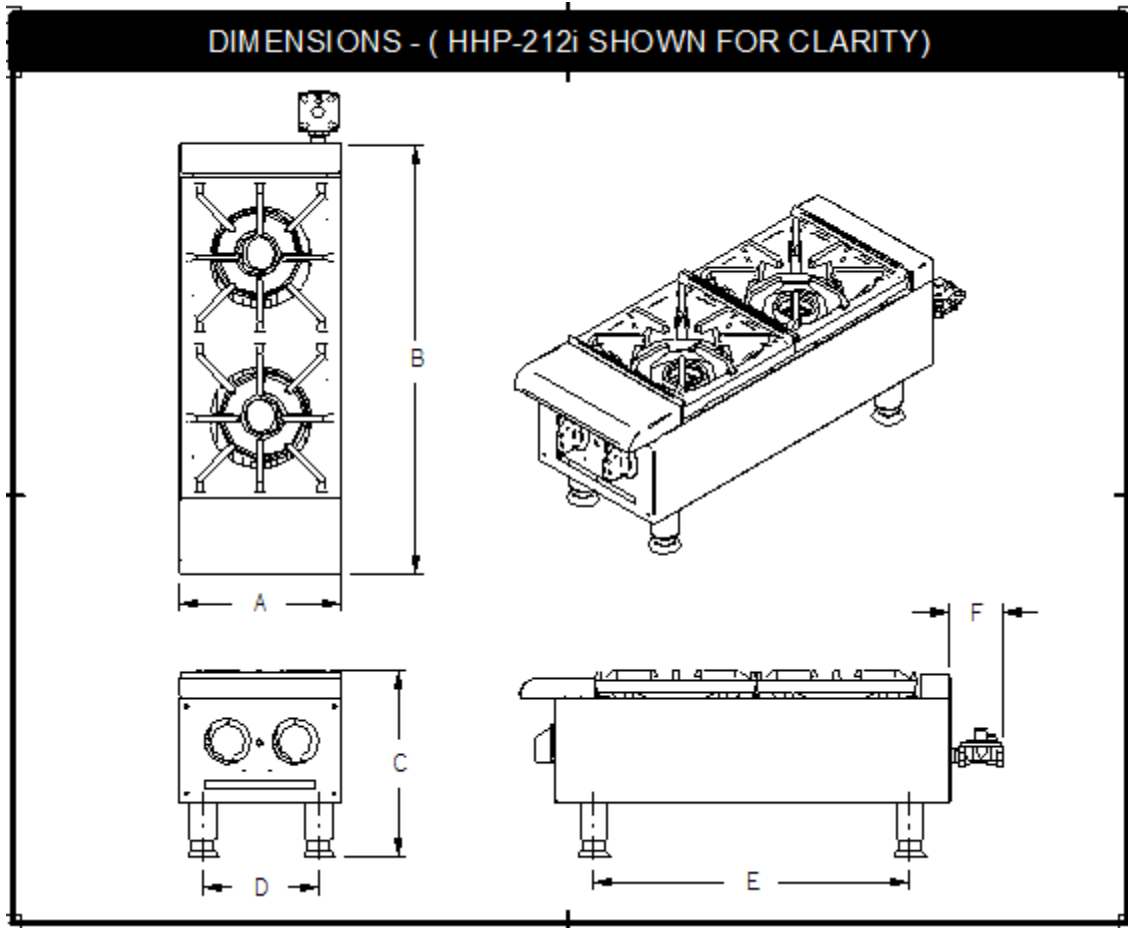

MODEL	# of BURNERS	BTU/hr PER BURNER NAT GAS	BTU/hr TOTAL NAT GAS	BTU/hr PER BURNER PROPANE	BTU/hr TOTAL PROPANE	in W.C. NAT GAS	In W.C. PROPANE
HHP-212i	2	30,000	60,000	25,000	50,000	5	10
HHP-424i	4	30,000	120,000	25,000	100,000	5	10
HHP-636i	6	30,000	180,000	25,000	150,000	5	10
HHP-848i	8	30,000	240,000	25,000	200,000	5	10
HHPS-212i	2	30,000	60,000	25,000	50,000	5	10
HHPS-424i	4	30,000	120,000	25,000	100,000	5	10
HHPS-636i	6	30,000	180,000	25,000	150,000	5	10
HHPS-848i	8	30,000	240,000	25,000	200,000	5	10

## 4. LIGHTING INSTRUCTIONS

HHP and HHPs Gas Open Burner Ranges are furnished with either a pilot safety valve or a standing pilot (not available in the European Community). Please follow the instructions for your unit.

### **Pilot Operation Flame Failure Gas Valve:**

Operation of the gas valve pilot:

1. Turn knob on the main gas valve to the pilot position
2. Depress knob to start gas flow to the pilot valve
3. Light pilot valve
  - a. Using a match or taper
4. Hold in knob for 15 to 30 seconds to heat up the thermocouple
5. Release knob and turn to the desired gas flow position
  - a. If pilot goes out repeat steps 1-4, some thermocouples will take longer to heat up

### **Standing Pilot Lighting Instructions (Not Available in the European Community)**

The pilot lights on the broilers have been set at the factory. A screwdriver may be required for the first lighting to adjust the flame for your elevation.

1. Turn off the manual shut off valve and wait 5 minutes to clear the gas.
2. Turn all knobs to the "OFF" position.
3. The valve can be accessed through an opening in the front panel or remove the cooking grates and light the pilot from above.
4. Turn the manual shut off valve on.
5. Hold an ignition source (match) to both openings on the pilot tube. When the flames are established, remove the ignition source.
6. Turn the burner knobs to "HI". If the burner does not ignite, promptly open the pilot valve more. If the pilot flame appears larger than necessary, turn it down and reset burner ignition. The pilot flame should be as small as possible but large enough to guarantee reliable ignition of the burners when the knobs are turned to "HI".

### **Relighting the Pilot**

If the pilot light should go out for any reason:

- Promptly shut off all gas at the manual shut off valve.
- Turn off all knobs and pilot valves; wait 5 minutes to clear gas.
- Relight following steps 4 through 6 under **Standing Pilot Lighting Instructions**.

### **Lighting the Main Burner**

Since the burner is lit from constantly burning pilot, turn knobs to "HI" to put the unit in operation; then adjust to any desired position between "LO" and "HI".

- To light burner, turn knob to "max." then back off to the desired flame level. The range of adjustment is virtually infinite between high and off. (At the small flame, there is a pre-set low).
- When the broiler is first heated, it will smoke until oil used in manufacturing, preservation and dust from storage and shipping are burned off. An hour at "max." on all burners is usually sufficient.
- Turn knobs off and let cool
- For first cooking, set the grates at maximum tilt position and preheat before broiling. You will have to experiment with knob settings and grate position for each particular item.
- Keep the grease/water pan with sufficient water to cover the entire bottom.
- Clean regularly. Grates may be removed for washing in the sink. Brush out carbonized particles. Thoroughly wash the grease/water pan.

### **CAUTION**

Never attempt to move a grill section while cooking. An unexpected flare could cause severe injury. Turn off the unit, let it cool and use potholders and/or gloves to reposition or remove. The space between the legs at the bottom admits combustion air, **DO NOT BLOCK THIS SPACE**.

### **Main burner air supply:**

For efficient burner operation, a proper balance of gas volume and primary air supply must be maintained which will result in complete combustion. Insufficient air supply results in a yellow streaming flame. Primary air supply is controlled by an air shutter on the front of the burner.

Loosen the screws on the front of the burner, and adjust the air shutter to just eliminate the yellow tips of the burner flame. Lock the air shutter in place by tightening the screws.

### **European Community:**

**If adjustment becomes necessary in the field, it should be done by a factory authorized and trained technician who should seal the screw after the adjustment to safeguard against unauthorized tampering by the end user.**

All burners are lit from constantly burning pilots. Turning the valve to the desired flame height is all that is required to put the unit in service.

Do not permit fans to blow directly at the unit. Wherever possible, avoid open windows next to the units' sides or back. Avoid wall type fans which create air cross-currents within a room.

It is also necessary that sufficient air should be allowed to enter the room to compensate for the amount of air removed by any ventilating system. Otherwise, a subnormal atmospheric pressure will occur, affecting operation and causing undesirable working conditions.

A properly designed and installed hood will act as the heart of the ventilating system for the room or area in which the unit is installed, and will leave the unit independent of changing draft conditions.

All valves must be checked and lubricated periodically. This must be done by an authorized service representative in your area.

## **5. MAINTENANCE**



**CAUTION:** Use only non-abrasive cleaners. Abrasive cleaners could scratch the finish of your unit, marring it's appearance and making it susceptible to dirt accumulation. Do Not use steel wool, other abrasive cleaners or cleaners/sanitizers containing chlorine, iodine, ammonia or bromine chemicals as these will deteriorate the stainless steel and glass material and shorten the life of the unit.



### **Daily:**

1. Thoroughly clean back, sides, top and front of unit.
2. Clean grates daily.

### **Weekly**

1. Clean unit thoroughly. Clean stainless steel or chromed surfaces with a damp cloth and polish with a soft, dry cloth. A detergent may be used for cleaning. To remove discolorations, use a non-abrasive cleaner.
2. To clean the drip pan: Remove the drip pan by grabbing the handle and pulling it out of the opening in the front panel. To replace the pan, reverse this procedure.
3. Burner air shutter openings must be kept clean.
4. Main burner ports must be kept clean. To clean burners, boil them in a strong solution of lye water for 15 to 20 minutes. Then either brush with a wire brush or clean gas ports with a sharp-pointed metal instrument to insure open ports.



**CAUTION:** Clean the regulator at least once a month. Make sure the vent opening is open and not blocked in any way. Failure to do so will cause variations in pressure. Your unit will not function as well and it could shorten the life of the product.



## 6. CONVERSION

- Instructions are for conversion from Natural Gas to Propane (L.P.) on all models BPHHP and BPHHPS.
- The conversion should be done before connecting the unit to the gas supply.
- Units are shipped from the factory equipped for use on natural gas. Orifices necessary for LP (propane) are provided in a bag tied to the valve on the front panel.
  - Remove the knobs and front panel.
  - Remove the orifice fittings from the valve. Change the orifices to the size recommended for propane (L.P).
  - Replace the orifice fittings into the valve.
- To change the regulator:

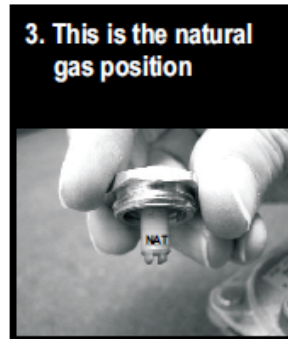
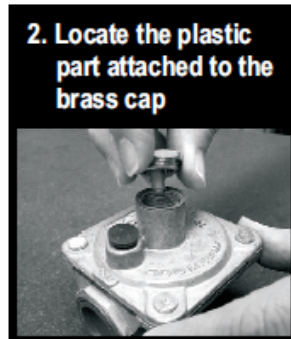

- Connect the regulator to the unit, connect gas and check for leaks. **WARNING:** Do not use an open flame to check for leaks.
- Check the system pressure. With the front panel removed remove the plug from the manifold.
- Place a fitting in the plug opening and connect a manometer.
- For Natural gas the pressure in the manifold should be 5" water column or 12.4 millibar. For LP the pressure in the manifold should be 10" water Column or 24.9 millibar.
- To adjust the pressure remove the brass cap and turn the white plastic part inside the stem of the regulator. See picture regulator 8.
- Take a wide straight screw driver and place it in the two notches shown in picture regulator 7 turn clockwise to increase pressure and counter-clockwise to reduce pressure. See picture regulator 8.
- Once the pressure has been adjusted replace the brass cap.
- Note the blue cap on the regulator, this is the vent there are openings below the top rim. **NEVER** block these openings your regulator will fail to operate correctly. On at least a monthly basis blow off any dust or grease which may accumulate around this cap. The openings must remain open for the regulator to function. Clean more often in a very greasy atmosphere.

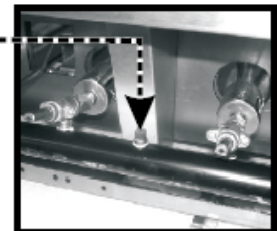





EXPLODED VIEW - HHP-2i SHOWN FOR CLARITY

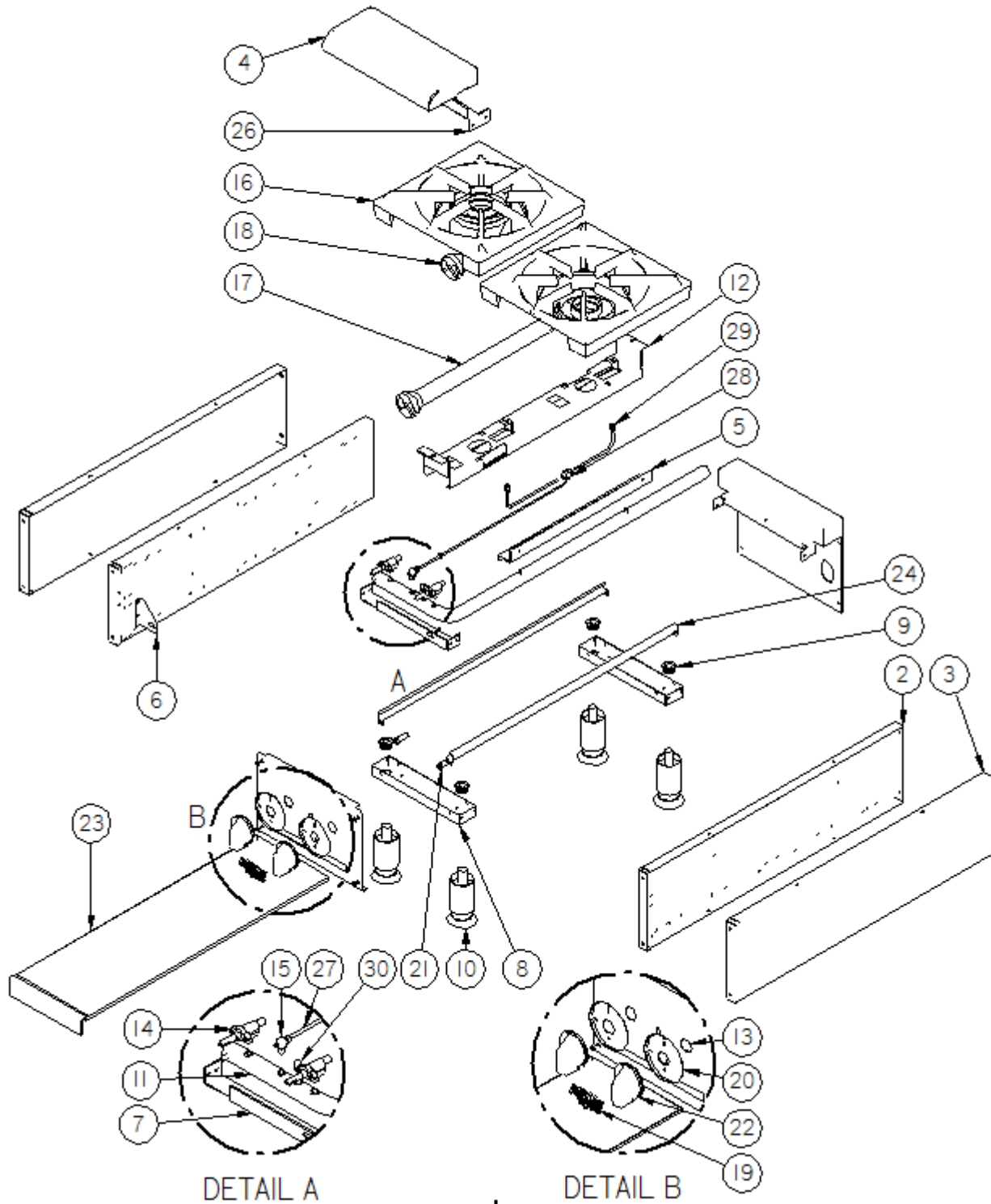

ITEM	PART #	DESCRIPTION	QTY
1	22361029	PANEL, BACK HHP-2I	1
2	22361257	PANEL, INNER S DE TSHHP I-LINE	2
3	22361254	PANEL S DE HHP HDI-LINE	2
4	22361038	BULLNOSE, HHP-2I	1
5	310270	COVER MANFOLD CHANNEL TSMGTSTG/36" RANG	1
6	310269	BARCKET, MANFOLD SUPPORT	1
7	350417	1 2" MANFOLD SUPPORT	1
8	22360005	SUPPORT, LEG HHP-2I	2
9	8430500	INSERT, 3/4-10 THREAD, PRESS-IN	4
10	8633700	LEG, HEAVY DUTY 2" DIA, W/ FOOT FLANGE	4
11	350425	MANFOLD	1
12	311282	HANGER, BURNER ECONOMY NEW	1
13	22261033	PANEL, CONTROL HHP-2I	1
14	2068000	VALVE, GAS, ON-OFF	2
15	2066643	VALVE, 90° PL OT 1/8" NPT X 3/16	1
16	311138	GRATE, TOP 12 X 12 LGHT	2
17	311140	BURNER LONG VENT URI ECONOMY RANGE VALVE	1
18	311139	BURNER SHORT VENT URI ECONOMY RANGE VALVE	1
19	2066847	LOGO, APWYOTT CASTED	1
20	8834900	DECAL, DIAL PLATE FOR MANUAL VALVES	2
21	301140	ORFCE HOOD #40 3/8-27 X 1-3/8"	2
22	8706320	KNOB, METAL COOKLINE, .375 D SHAFT NO LOGO	2
23	22360010	WELDMT, DRIP PAN HHP-2I	1
24	21827026	SUPPORT, DRIP PAN HHP-2H	2
25	8134900	8-32 X 3/8 TR HD	4
26	350416	ANGLE, TSHP-12	1
27	310328	TUBING, PLOT RANGE JUNCTION	1
28	300177	TEE, 3/16 COMPRESSION	1
29	310327	TUBING PLOT SUPPY RANGE	2
30	2092517	PLUG, 1/8 NPTM	1

## APW WYOTT EQUIPMENT LIMITED WARRANTY

APW Wyott Foodservice Equipment Company warrants its equipment against defects in materials and workmanship, subject to the following conditions:

This warranty applies to the original owner only and is not assignable.

Should any product fail to function in its intended manner under normal use within the limits defined in this warranty, at the option of APW Wyott such product will be repaired or replaced by APW Wyott or its Authorized Service Agency. APW Wyott will only be responsible for charges incurred or service performed by its Authorized Service Agencies. The use of other than APW Wyott Authorized Service Agencies will void this warranty and APW Wyott will not be responsible for such work or any charges associated with same. The closest APW Wyott Authorized Service Agent must be used.

This warranty covers products shipped into the 48 contiguous United States, Hawaii, metropolitan areas of Alaska and Canada. There will be no labor coverage for equipment located on any island not connected by roadway to the mainland.

Warranty coverage on products used outside the 48 contiguous United States, Hawaii, and metropolitan areas of Alaska and Canada may vary. Contact the international APW Wyott distributor, dealer, or service agency for details.

### Time Period

One year for parts and one year for labor, effective from the date of purchase by the original owner. The Authorized Service Agency may, at their option, require proof of purchase. Parts replaced under this warranty are warranted for the un-expired portion of the original product warranty only.

### Exceptions

- \***Gas/Electric Cookline:** Models GCB, GCRB, GF, GGM, GGT, CHP-H, EF, EG, EHP. Three (3) Year Warranty on all component parts, except switches and thermostats. (2 additional years on parts only. No labor on second or third year.)
- \***Broiler Briquettes, Rock Grates, Cooking Grates, Burner Shields, Fireboxes:** 90 Day Material Only. No Labor.
- \***Heat Strips:** Models FD, FDL, FDD, FDDL. Two (2) Year Warranty on element only. No labor second year.
- \***Glass Windows, Doors, Seals, Rubber Seals, Light Bulbs:** 90 Day Material Only. No Labor.

In all cases, parts covered by extended warranty will be shipped FOB the factory after the first year.

### Portable Carry In Products

Equipment weighing over 70 pounds or permanently installed will be serviced on-site as per the terms of this warranty. Equipment weighing 70 pounds or under, and which is not permanently installed, i.e. with cord and plug, is considered portable and is subject to the following warranty handling limitations. If portable equipment fails to operate in its intended manner on the first day of connection, or use, at APW Wyott's option or its Authorized Service Agency, it will be serviced on site or replaced.

From day two through the conclusion of this warranty period, portable units must be taken to or sent prepaid to the APW Wyott Authorized Service Agency for in-warranty repairs. No mileage or travel charges are allowed on portable units after the first day of use. If the customer wants on-site service, they may receive same by paying the travel and mileage charges. Exceptions to this rule: (1) countertop warmers and cookers, which are covered under the Enhanced Warranty Program, and (2) toasters or rollergrills which have in store service.

### Exclusions

The following conditions are not covered by warranty:

- \*Equipment failure relating to improper installation, improper utility connection or supply and problems due to ventilation.
- \*Equipment that has not been properly maintained, calibration of controls, adjustments, damage from improper cleaning and water damage to controls.
- \*Equipment that has not been used in an appropriate manner, or has been subject to misuse or misapplication, neglect, abuse, accident, alteration, negligence, damage during transit, delivery or installation, fire, flood, riot or act of god.
- \*Equipment that has the model number or serial number removed or altered.

If the equipment has been changed, altered, modified or repaired by other than an Authorized Service Agency during or after the warranty period, then the manufacturer shall not be liable for any damages to any person or to any property, which may result from the use of the equipment thereafter.

This warranty does not cover services performed at overtime or premium labor rates. Should service be required at times which normally involve overtime or premium labor rates, the owner shall be charged for the difference between normal service rates and such premium rates. APW Wyott does not assume any liability for extended delays in replacing or repairing any items beyond its control.

In all cases, the use of other than APW Wyott Authorized OEM Replacement Parts will void this warranty.

This equipment is intended for commercial use only. Warranty is void if equipment is installed in other than commercial application.

### Water Quality Requirements

Water supply intended for a unit that has in excess of 3.0 grains of hardness per gallon (GPG) must be treated or softened before being used. Water containing over 3.0 GPG will decrease the efficiency and reduce the operation life of the unit.

**Note: Product failure caused by liming or sediment buildup is not covered under warranty.**

**"THE FOREGOING WARRANTY IS IN LIEU OF ANY AND ALL OTHER WARRANTIES EXPRESSED OR IMPLIED INCLUDING ANY IMPLIED WARRANTY OF MERCHANTABILITY OR FITNESS FOR PARTICULAR PURPOSES AND CONSTITUTES THE ENTIRE LIABILITY OF APW WYOTT. IN NO EVENT DOES THE LIMITED WARRANTY EXTEND BEYOND THE TERMS STATED HEREIN."**

9/05