

THERMA-TEK COUNTER SERIES RANGE CORP.

OWNERS MANUAL AND INSTALLATION INSTRUCTIONS

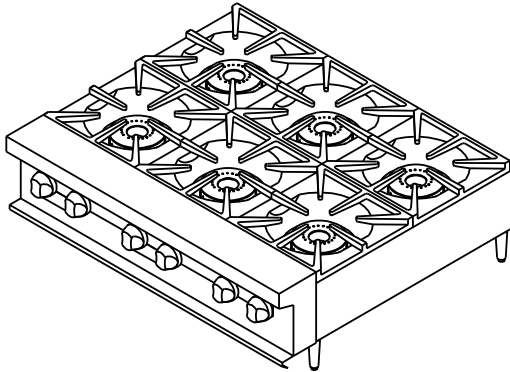

MODEL # TC36-6 (shown)

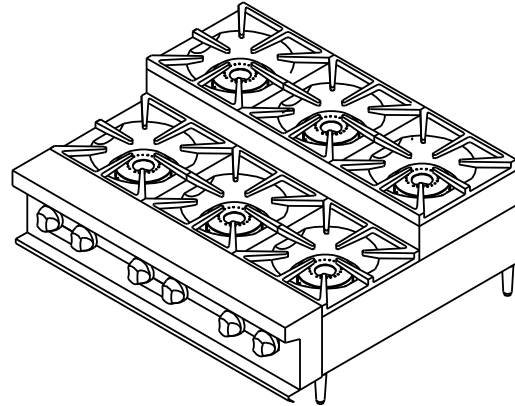

MODEL # TCHP36SU-6 (shown)

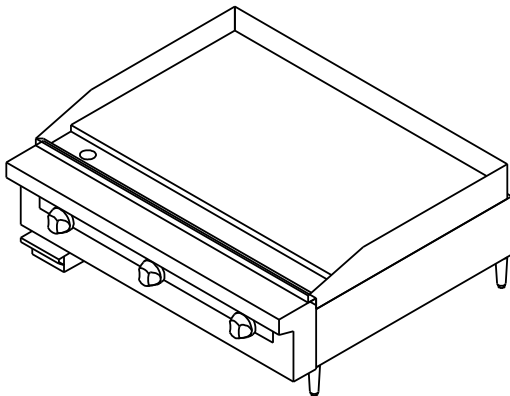

MODEL # TC36G (shown)

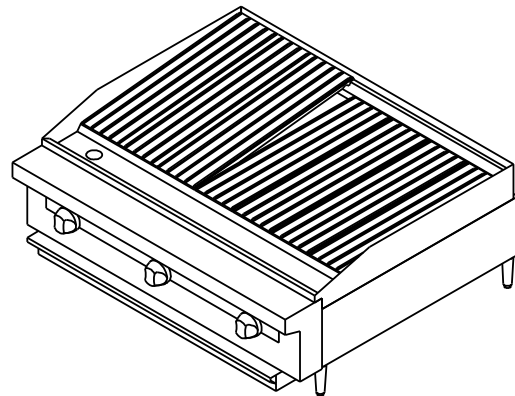

MODEL # TC36RB (shown)



Made in U.S.A

THERMA-TEK RANGE CORP.

INTRODUCTION/ SAFETY PRECAUTIONS

Thank you for choosing your new THERMA-TEK Equipment. Our Products are designed to be safe and reliable when properly cared for and used reasonably. Your service agency or dealer recommends periodic inspections. Installation, maintenance, and repairs should be performed by your local authorized service agency. **This equipment is not intended for home use.**

This equipment is for commercial use by trained professionals familiar with commercial cooking equipment. It is the responsibility of the Supervisor or equivalent person to ensure that users wear suitable protective clothing and safety gear. Caution: some parts of the equipment become very hot and will cause burns if accidentally touched.

FOR YOUR SAFETY

DO NOT STORE OR USE GASOLINE OR OTHER FLAMMABLE VAPORS OR LIQUIDS IN THE VICINITY OF THIS OR ANY OTHER APPLIANCE.

FOR YOUR SAFETY

If you smell gas:

1. Shut off gas to appliance.
2. Extinguish any open flame.
3. If odor continues, immediately call your gas supplier.

Consult your local gas supplier for instructions to be followed in the event you smell gas.
Post these instructions in a prominent location.

WARNING: IMPROPER INSTALLATION, ADJUSTMENT ALTERATION, SERVICE OR MAINTENANCE CAN CAUSE PROPERTY DAMAGE, INJURY OR DEATH. READ THE OWNERS/INSTALLERS MANUAL THOROUGHLY BEFORE INSTALLING OR SERVICING THIS EQUIPMENT.

CALIFORNIA PROPOSITON 65 – WARNING

The burning of gas cooking fuel generates some by- products which are on the list of substances known by the State of California to cause cancer or reproductive harm. California law requires businesses to warn customers of potential exposure to such substances. To minimize exposure to these substances, always operate this unit according to the owners/installation manual, ensuring you provide good ventilation when cooking with gas.

PLEASE RETAIN THESE INSTRUCTIONS FOR FUTURE REFERENCE

INSTALLATION AND SAFETY GUIDELINES

IMPORTANT

Safe and satisfactory operation of your equipment depends on its proper installation. Installation must conform to local codes, or in the absence of local codes with the National Fuel Code ANSI Z223.1 (latest edition).

All THERMA-TEK appliances are shipped with a gas pressure regulator packed with the unit. All units are adjusted, tested, and inspected at the factory prior to shipment.

After uncrating, immediately check the equipment for visible signs of shipping damage. If such damage has occurred, do not refuse shipment, but contact the shipper and file appropriate freight claims.

GENERAL

- Installation of this equipment should be made by licensed and authorized personnel.
- A manual gas shut-off valve must be installed in the gas supply (service) line ahead of the appliance and gas pressure regulator installed in the gas stream for safety and ease of future service.
- The gas pressure regulator supplied must be installed on the appliance prior to connecting the equipment to the gas line. Failure to install a regulator will void the equipment warranty and result in a potentially hazardous condition.
- The appliance and its individual shut off valve must be disconnected from the gas supply system during any pressure testing of that system in excess of ½ PSI.
- The appliance must be isolated from the gas supply system by closing its individual shut off valve during any pressure testing of the gas supply piping system at test pressure equal to or less than ½ PSI.
- Please contact the factory, the factory representative, or a local authorized service company to perform maintenance and repairs.

RATING PLATE

Information on this plate includes the model and serial number. When communicating with the factory about a unit or requesting special parts or information, this information is required for proper identification. Other information on the plate is the BTU/hr input of the burners, gas pressure in inches WC, and whether the unit has orifices for natural or propane gas.

IMPORTANT: The appliance must be connected only to the type of gas identified on the rating plate.

GAS CONVERSION

We recommend that the appliance be ordered from the factory for the type of gas at the installation site. When gas conversion is necessary contact the factory for a proper gas conversion kit.

INSTALLATION AND SAFETY GUIDELINES

CLEARANCES

- The unit must be kept clear of all combustibles.
- The unit must be installed with the 4” legs supplied for proper operation.
- Minimum clearance from combustible construction:

	<u>Side</u>	<u>Back</u>
○ Open top	12”	12”
○ Griddle	6”	12”
- Minimum clearance from non-combustible:

	<u>Side</u>	<u>Back</u>
• Open top	0”	0”
• Broiler	0”	0” (For use in noncombustible locations only)
• Griddle	0”	6”

LEVELING

A carpenter’s spirit level should be placed on the cooking surface and the unit leveled side-to-side, and front to back. If it is not level, burner combustion may be erratic or the unit may not function efficiently.

AIR SUPPLY AND VENTILATION

The area around the appliance must be kept clear to avoid any obstructions of the flow of combustion and ventilation air as well as for ease of maintenance, service, and proper appliance operation. Keep clearance for openings into the combustion chamber and adequate air supply. Means must be provided for any commercial, heavy duty-cooking appliance to exhaust combustion wastes to the outside of the building.

Air movement should be checked during installation. Strong exhaust fans in the hood or in the overall air conditioning system can produce a slight draft in the room, which can interfere with pilot or burner performance. If pilot or burner problems persist, make up air openings or baffles may have to be provided in the room.

Filters and drip troughs should be part of any industrial hood, but consult local codes before constructing and installing any hood. The duct system, exhaust hood, and filter bank must be cleaned on a regular basis and kept free of grease.

ALTITUDE

The appliance input rating (BTU/hr) is for elevations up to 2000 feet. For elevations above 2000 feet, the rate should be reduced 4% for each 1000 feet above sea level. The correct orifices are installed at the factory if the operating altitude is known at the time of sale.

INSTALLATION AND SAFETY GUIDELINES

GAS CONNECTION

The gas supply (service) line must be at least the same size or larger than the inlet line of the appliance. CHEFTECH counter equipment is supplied with a ¾" NPT Schedule 40 inlet. Sealant on all pipe joints must be resistive to LP gas.

MANUAL SHUT-OFF VALVE

A manual shut-off valve must be installed in the gas service line ahead of the appliance and regulator in the gas stream and in a position where it can be reached quickly in the event of an emergency. The manual shut-off valve is supplied by the installer.

PRESSURE REGULATOR

All commercial cooking equipment must have a pressure regulator on the incoming service line for safe and efficient operation, since pressure may fluctuate on local demand. A regulator is supplied with the appliance. **Failure to install a pressure regulator will void the equipment warranty.** The regulators are adjusted at the factory, 5.0" WC for natural gas, and 10.0" WC for propane gas. Ensure the supply pressure is within the following range: Natural Gas 6.0" WC to 13.0" WC / Propane Gas 11.0" WC to 13.0" WC. Any adjustments to the regulators must be made *only* by qualified service personnel with proper test equipment.

RIGID CONNECTIONS

Double check any installer supplied gas pipes visually and blow them out with compressed air to clear any dirt particles, threading chips, or any other foreign matter before installing a service line. Those particles will clog orifices when gas pressure is applied. All connections must be sealed with a joint compound for LP gas and tested with a soapy water solution before lighting any pilots.

FLEXIBLE COUPLINGS, CONNECTORS AND CASTERS

If the unit is to be installed with flexible coupling and or quick disconnect fittings, the installer must use a heavy duty commercial flexible connector at least ¾" NPT (with suitable strain relief) in compliance with the standard for connectors for movable gas appliances, ANSI Z21.69-1987 and Addenda Z2.169a-1989 (or latest edition) or connectors for movable appliances, CAN/CGA-6.16 (or latest edition) and quick disconnect device must comply with the standard for quick disconnect devices for use with gas fuel, ANSI Z21.41-1989 (or latest edition) or quick disconnect devices for use with gas fuel, CAN1-69 (or latest edition). Adequate means must be provided to limit the movement of the appliance. Domestic connectors are not suitable.

When the appliance is supplied with casters and is connected to the supply piping by means of a connector for movable appliances, and if disconnecting the restraint is necessary, this restraint must be reconnected after the appliance is returned to its original installation position. The strain relief is a cable attached to the rear of the appliance.

INITIAL START-UP

All THERMA-TEK appliances are adjusted and tested before leaving the factory. Adjustments and calibrations may be necessary upon installation to meet local conditions, low gas characteristics; problems caused by rough handling or vibration during shipping, and are to be performed only by qualified service personnel. These adjustments are the responsibility of the customer and or dealer and are not covered by our warranty.

Check all gas connections for leaks with a soapy water solution before lighting pilots. **Do NOT use an open flame to check for leaks.** Putting an open flame beside a new gas connection is extremely dangerous. Before lighting any pilots, make sure that burner valves and thermostats are in the off position.

LIGHTING THE PILOTS

CAUTION: When lighting the pilots and checking for leaks, do not stand with your face close to the Combustion chamber.

OPEN TOP:

- Remove top grates
- Make sure pilot adjust valve located on the manifold is open.
- Light the pilot and adjust flame to approximately ½”.

GRIDDLE:

- Looking through slot in the valve panel, locate pilot lighting holes in the burner front shield.
- Make sure pilot adjust valve located on the manifold is open.
- Light the pilot and adjust flame to approximately ¾” high.

BROILER:

- Remove grates.
- Make sure pilot adjust valve located on the manifold is open.
- Light the pilot and adjust the flame to approximately ¾” high.

SHUTDOWN

- Nightly shutdown: Turn burner valves and thermostat to off position, pilots will remain lit.
- Complete shutdown: Turn burner valves and thermostats to off position. Turn main gas supply to range off.

OPERATING INSTRUCTIONS

BEFORE USE

All units are wiped clean with solvents at the factory to remove any visible signs of dirt, oil or grease remaining from the manufacturing process.

Open Tops & Broilers

The Top grates should be removed and washed before use. With these removed it will be possible to remove plastic ties holding the burners in place for shipment.

Griddle

New griddles should be seasoned as follows:

1. Clean the griddle surface thoroughly with hot soapy water to remove the protective oil coating wiped on at the factory.
2. Rinse with a mixture of ¼ cup vinegar to one-quart water.
3. Spread unsalted shortening or liquid frying compound evenly over the entire griddle surface.
4. Turn all griddle burners to medium or thermostats to 350 degrees and wait until the shortening begins to smoke, and then turn the burners off.
5. Rub the now melted shortening into the griddle surface with a cloth covering the entire surface.
6. Let the griddle cool, and then repeat steps 3, 4, & 5.
7. When the griddle is cool after the second seasoning, wipe it once again with a thin film of shortening or cooking oil.

OPERATING SUGGESTIONS

Open Tops

Open top burners are quickly lighted and require no preheating time. Light only as many burners as needed.

Broiler

Allow the grates to thoroughly heat before using. During slow periods heat only the portion required.

Griddle

Heat the griddle thoroughly before using. During slow periods the top can be kept warm with the burners turned partially down, or heat only the portion of the griddle required.

CARE AND CLEANING

Any piece of equipment works better and lasts longer when properly maintained. Cooking equipment is no exception. Your THERMA-TEK appliance must be kept clean during the workday and thoroughly cleaned at the end of the day.

OPEN TOP

- Remove grates and burners and wash thoroughly with hot soapy water. Be sure to clean burner ports by using a piece of wire
- Make sure air shutter openings are clear of any debris.
- Make sure pilot flashtubes are clear.

BROILER

- Remove large pieces of food residue and carefully scrape spillovers from the drip tray below the cooking surface.
- Cast iron grates should be scraped with a wire brush frequently, and periodically soaked in hot water to remove grease from the pores of the cast iron. Never expose the grates to extreme heat for the purpose of burning off excess grease. This practice will shorten the life of the grates.
- The lava rock in the Char-rock broiler are highly porous and relatively self-cleaning. High heat will effectively clean and burn off grease. The lava rock should be turned over about every week depending on the amount of cooking being done and the type of food being prepared.

GRIDDLE

- Scrape with a nylon griddle scraper to remove cooked on spills. Use a fine-grained stone only when absolutely necessary.
- Wipe away any griddle stone dust and food particles with a cloth.
- Wash with hot soapy water, then rinse with vinegar and water solution.
- Then rinse again with clean water.
- Re-oil with shortening or liquid frying compound.
- Remove grease can, empty, and clean it thoroughly with hot soapy water.
- Never flood the griddle with cold water. This promotes griddle warping and can cause the griddle plate to crack if continued over a long period of time.

STAINLESS STEEL

- All stainless steel body parts should be wiped regularly with hot soapy water during the day and with a liquid cleaner designed for this material at the end of each day. Do not use steel wool, abrasive cloths, cleansers, or powders to clean stainless steel surfaces. If it is necessary to scrape stainless steel to remove encrusted materials, soak in hot water to loosen the material, then use a nylon or wood scraper to loosen debris. Never use a spatula, knife or any other metal tool to scrape stainless steel. These tools will scratch the stainless steel.

TROUBLESHOOTING

PROBLEM	POSSIBLE CAUSE	SOLUTION
Burner flame too large.	Incorrect pressure setting or orifice.	Check pressure setting and orifice.
Burner flame soft and yellow tipping.	Insufficient primary air.	Check air shutter setting.
Flame lifts off burner ports	Excessive primary air.	Check air shutter setting.
Flame lights back to orifice	Excessive primary air	Check air shutter setting.
Delayed ignition	1) Pilot flame too small. 2) Burner ports blocked. 3) Incorrect air shutter setting. 4) Incorrect pressure setting. 5) Pilot lighter tube dirty or blocked.	1) Check pilot flame length. 2) Clean burner ports. 3) Check air shutter setting. 4) Check pressure setting. 5) Clean tube.
Pilot burner will not ignite	1) Pilot blocked or dirty. 2) Pilot adjusting screw closed.	1) Clean pilot. 2) Open & adjust flame length.
Griddle too hot or not hot enough.	Thermostat out of calibration.	Check calibration.

HOW TO OBTAIN SERVICE

For warranty service, contact your local THERMA-TEK authorized service agency. Provide him or her with the Model #, Serial #, date of installation, and a brief description of the problem. If you need assistance locating the authorized service agency in your area, contact your local dealer. He or she will have a listing of authorized dealers in your area, or on the web www.therma-tek.com

We want you to remain a satisfied customer. If a problem arises that cannot be resolved to your satisfaction, please contact our customer service at:

714-968-7498

714-968-3529 (fax)

877-THERTEK (toll free)

Or e-mail us at infor@therma-tek.com

For technical support call: 570-455-3000
866-826-8993

HOT PLATE (Counter Series)

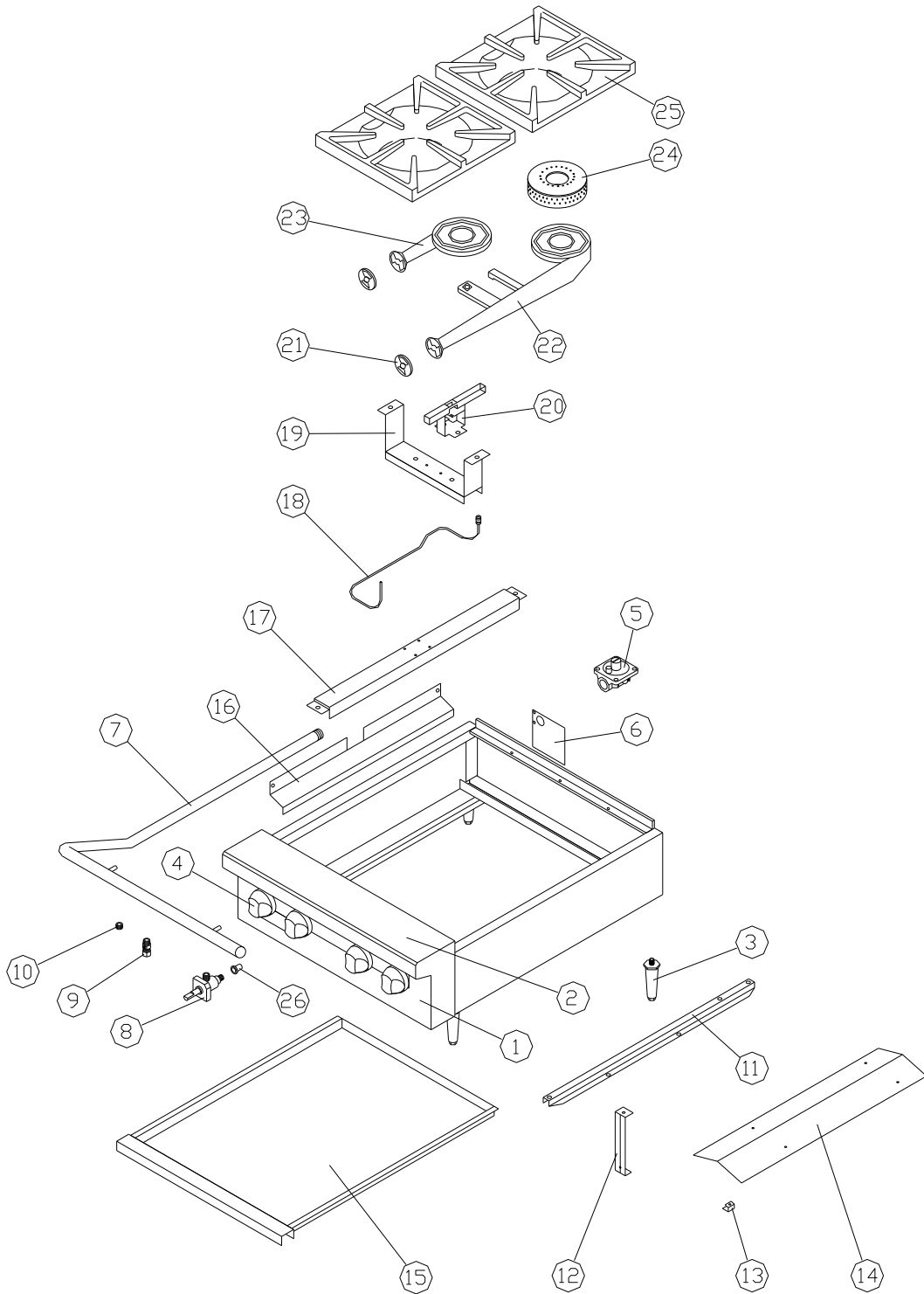

Item Number	Part No.	Description	Qty Required					
			12"	24"	36"	48"	60"	72"
1	31038-01	Front Panel 12"	1					
	31038-02	Front Panel 24"		1				
	31038-03	Front Panel 36"			1			
	31038-04	Front Panel 48"				1		
	31038-05	Front Panel 60"					1	
	31038-06	Front Panel 72"						1
2	30103-01	Front Rail W/A 12"	1					
	30103-02	Front Rail W/A 24"		1				
	30103-03	Front Rail W/A 36"			1			
	30103-04	Front Rail W/A 48"				1		
	30103-05	Front Rail W/A 60"					1	
	30103-06	Front Rail W/A 72"						1
3	80034	4" leg	4	4	4	4	6	6
4	80000	Plastic Knob	2	4	6	8	10	12
5	80026-01	Regulator 5" Nat	1	1	1	1	1	1
	80026-02	Regulator 10" LP	1	1	1	1	1	1
6	30192	Tailpipe Bracket	1	1	1	1	1	1
7	81021-01	Manifold Pipe 12"	1					
	81021-02	Manifold Pipe 24"		1				
	81021-03	Manifold Pipe 36"			1			
	81021-04	Manifold Pipe 48"				1		
	81021-05	Manifold Pipe 60"					1	
	81021-06	Manifold Pipe 72"						1
8	80030	Manual Gas Valve	2	4	6	8	10	12
9	81018	Pilot Adjust Valve	1	2	3	4	5	6
10	81003-01	1/8 NPT Pipe Plug	1	1	3	3	3	5
11	30194	Drip Tray Slide				1	1	1
12	30193	Center Support Bracket				2	4	4
13	30200	Center Drip Shield Bracket				4	4	4
14	30199	Center Drip Shield				1	1	1
15	30195-01	12" Drip Tray	1					
	30195-02	24" Drip Tray		1		2		
	30195-03	36" Drip Tray			1			2
	30195-04	29 5/8" Drip Tray					1	
	30195-05	23 1/2" Drip Tray					1	
16	30197	Drip Shield	1	1	1	1	1	1
17	30196	Grate Support		1	2	3	4	5
18	90002	Open Top Pilot Assy	1	2	3	4	5	6
19	30102	Burner Rest	1	2	3	4	5	6
20	30473	Open Top Pilot Tube W/A	1	2	3	4	5	6
21	80029-01	Air Shutter	2	4	6	8	10	12
22	82049	Rear Venturi	1	2	3	4	5	6
23	82048	Front Venturi	1	2	3	4	5	6
24	82000	Burner Head	2	4	6	8	10	12
25	82051	Top Grate	2	4	6	8	10	12
26	81022-40	Orifice Drill #40 (Nat)	2	4	6	8	10	12
	81022-53	Orifice Drill #53 (LP)	2	4	6	8	10	12

GRIDDLE (Counter Series)

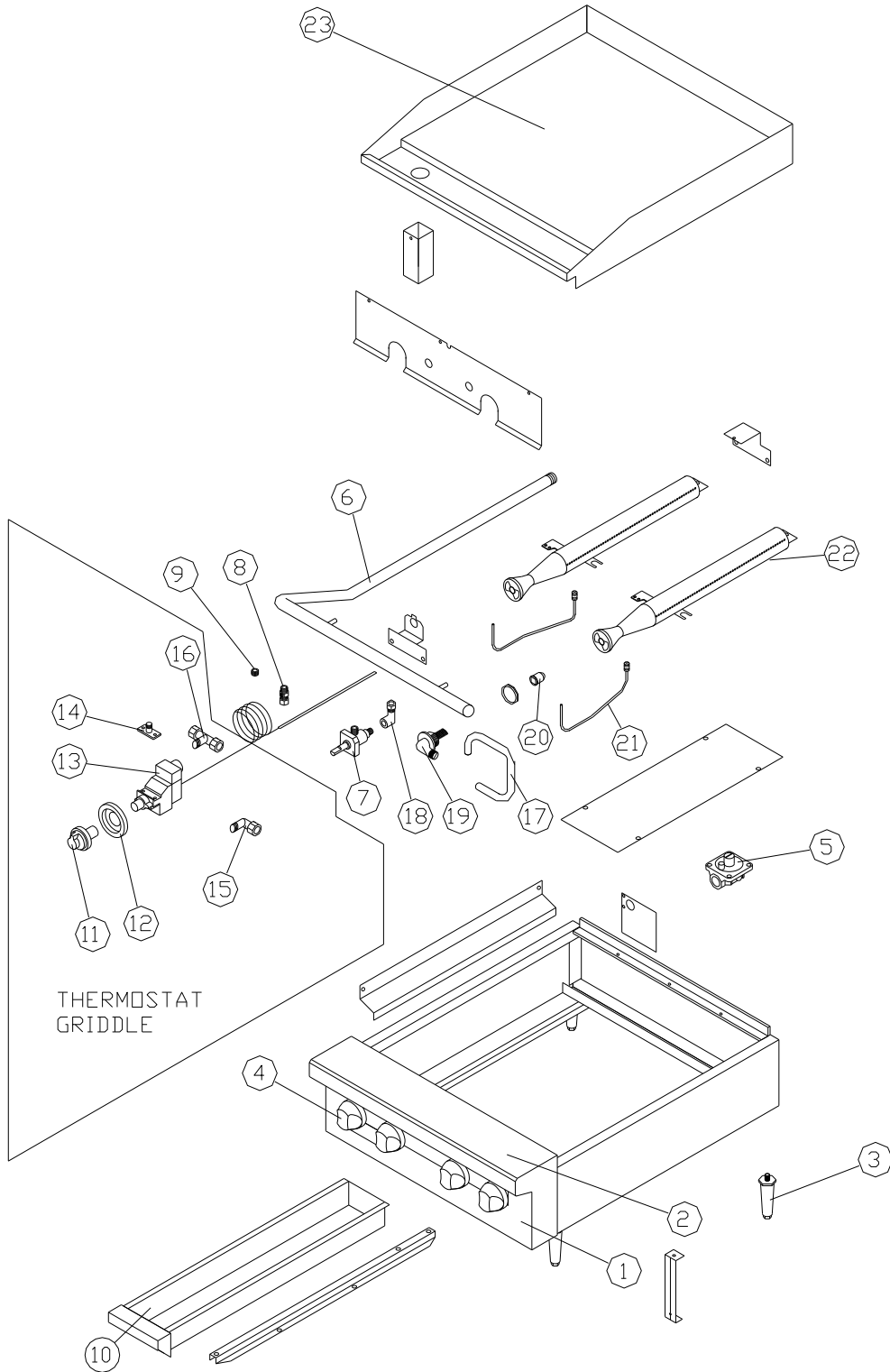

Item Number	Part No.	Description	Qty Required					
			12"	24"	36"	48"	60"	72"
1	31038-01	Front Panel 12"	1					
	31038-02	Front Panel 24"		1				
	31038-03	Front Panel 36"			1			
	31038-04	Front Panel 48"				1		
	31038-05	Front Panel 60"					1	
	31038-06	Front Panel 72"						1
2	30103-01	Front Rail W/A 12"	1					
	30103-02	Front Rail W/A 24"		1				
	30103-03	Front Rail W/A 36"			1			
	30103-04	Front Rail W/A 48"				1		
	30103-05	Front Rail W/A 60"					1	
	30103-06	Front Rail W/A 72"						1
3	80034	4" leg	4	4	4	4	6	6
4	80000	Plastic Knob	1	2	3	4	5	6
5	80026-01	Regulator 5" Nat	1	1	1	1	1	1
	80026-02	Regulator 10" LP	1	1	1	1	1	1
6	81021-01	Manifold Pipe 12"	1					
	81021-02	Manifold Pipe 24"		1				
	81021-03	Manifold Pipe 36"			1			
	81021-04	Manifold Pipe 48"				1		
	81021-05	Manifold Pipe 60"					1	
	81021-06	Manifold Pipe 72"						1
7	80030	Manual Gas Valve	1	2	3	4	5	6
8	81018	Pilot Adjust Valve	1	2	3	4	5	6
9	81003-01	1/8 NPT Pipe Plug	1	1	3	3	3	5
10	30221	Griddle Bucket	1	1	1	1	2	2
11	80015-01	BJ Thermostat Knob Griddle	1	1	2	2	3	3
12	80014	BJ Bezel	1	1	2	2	3	3
13	80017-01	BJWA Griddle Thermostat	1	1	2	2	3	3
14	80019	TEE Thermostat	1	1	2	2	3	3
15	81015	90 Elbow 3/8 CC x 1/4 NPT	1		1		1	
16	81027	TEE 3/8 CC 1/4 NPT			1	2	3	3
17	90013	3/8 x 8 Flexible Gas Tubing	1	2	3	4	5	6
18	81014	Elbow 3/8 TOD-3/8-27 UNS	1	2	3	4	5	6
19	81016-01	Orifice Elbow 3/8-27 x 3/8CC	1	2	3	4	5	6
20	81022-39	Orifice Drill #39 (Nat)	1	2	3	4	5	6
	81022-52	Orifice Drill #52 (LP)	1	2	3	4	5	6
21	90038	Pilot Tip Assy 3/16 x 12.5 Lg	1	2	3	4	5	6
22	80022	Burner Assembly	1	1	2	3	3	3
23	30215-01	Griddle W/A 12"	1					
	30215-02	Griddle W/A 24"		1				
	30215-03	Griddle W/A 36"			1			
	30215-04	Griddle W/A 48"				1		
	30215-05	Griddle W/A 60"					1	
	30215-06	Griddle W/A 72"						1
	30215-07	Thermostat Griddle W/A 12"	1					
	30215-08	Thermostat Griddle W/A 24"		1				
	30215-09	Thermostat Griddle W/A 36"			1			
	30215-10	Thermostat Griddle W/A 48"				1		
	30215-11	Thermostat Griddle W/A 60"					1	
	30215-12	Thermostat Griddle W/A 72"						1

BROILER (Counter Series)

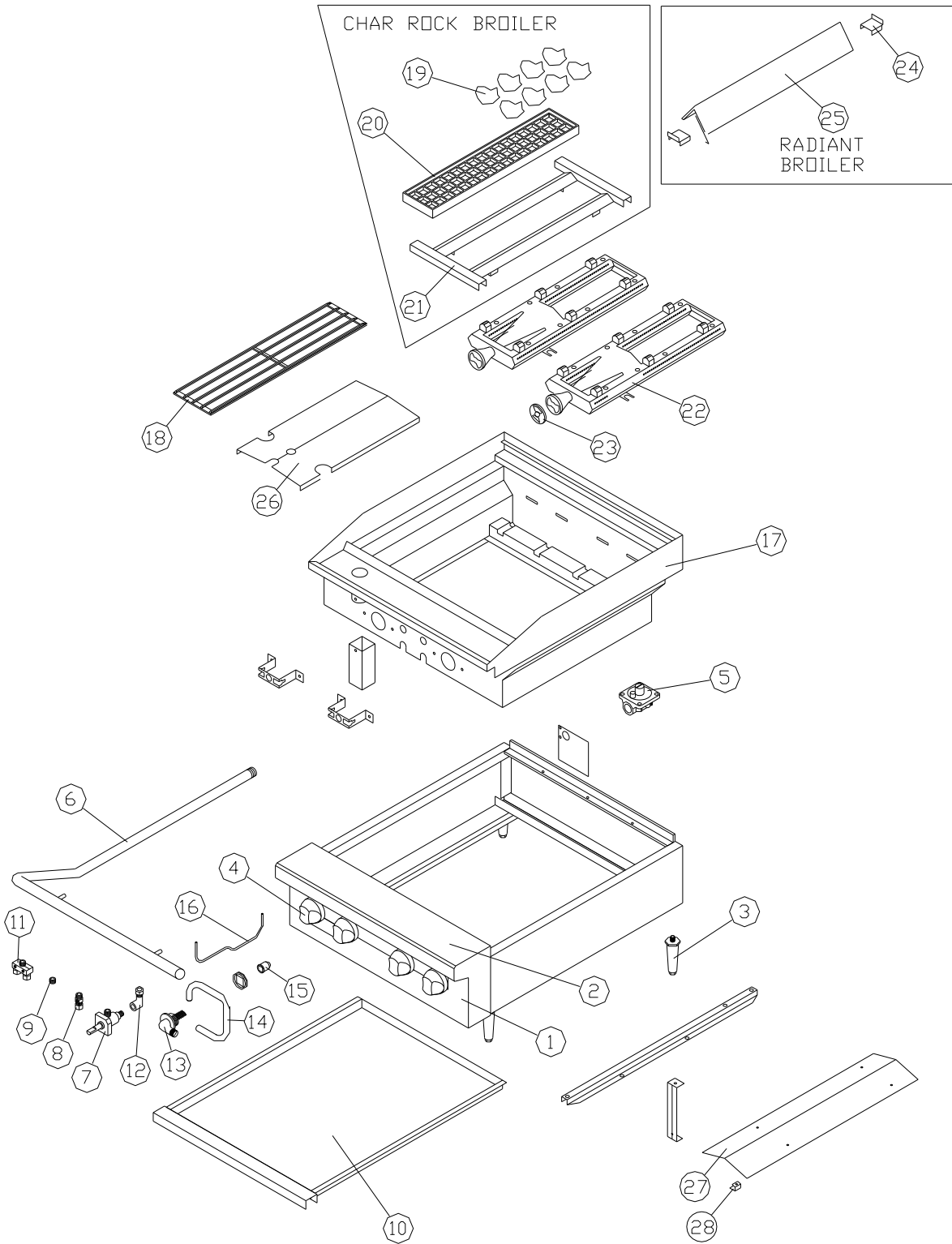

Item Number	Part No.	Description	Qty Required					
			12"	24"	36"	48"	60"	72"
1	31038-01	Front Panel 12"	1					
	31038-02	Front Panel 24"		1				
	31038-03	Front Panel 36"			1			
	31038-04	Front Panel 48"				1		
	31038-05	Front Panel 60"					1	
	31038-06	Front Panel 72"						1
2	30103-01	Front Rail W/A 12"	1					
	30103-02	Front Rail W/A 24"		1				
	30103-03	Front Rail W/A 36"			1			
	30103-04	Front Rail W/A 48"				1		
	30103-05	Front Rail W/A 60"					1	
	30103-06	Front Rail W/A 72"						1
3	80034	4" leg	4	4	4	4	6	6
4	80000	Plastic Knob	2	4	6	8	10	12
5	80026-01	Regulator 5" Nat	1	1	1	1	1	1
	80026-02	Regulator 10" LP	1	1	1	1	1	1
6	81021-01	Manifold Pipe 12"	1					
	81021-02	Manifold Pipe 24"		1				
	81021-03	Manifold Pipe 36"			1			
	81021-04	Manifold Pipe 48"				1		
	81021-05	Manifold Pipe 60"					1	
	81021-06	Manifold Pipe 72"						1
7	80030	Manual Gas Valve	1	2	3	4	5	6
8	81018	Pilot Adjust Valve	1	2	3	4	5	6
9	81003-01	1/8 NPT Pipe Plug	1	4	6	8	11	13
10	30195-01	12" Drip Tray	1					
	30195-02	24" Drip Tray		1		2	1	
	30195-03	36" Drip Tray			1		1	2
	30195-04	29 5/8" Drip Tray					1	
	30195-05	23 1/2" Drip Tray						1
11	81026	Pilot Valve TEE 3/16	1					
12	81014	Elbow 3/8 TOD-3/8-27 UNS	1	2	3	4	5	6
13	81016-01	Orifice Elbow 3/8-27 x 3/8 CC	1	2	3	4	5	6
14	90013	3/8/x 8 Flexible Gas Tubing	1	1	2	2	3	3
15	81022-39	Orifice Drill #39 (Nat)	1	2	3	4	5	6
	81022-52	Orifice Drill #52 (LP)	1	2	3	4	5	6
16	90038	Pilot Tip Assy 3/16 x 12.5 Lg	1	2	3	4	5	6
17	30253-01	Broiler Top W/A 12"	1					
	30253-02	Broiler Top W/A 24"		1				
	30253-03	Broiler Top W/A 36"			1			
	30253-04	Broiler Top W/A 48"				1		
	30253-05	Broiler Top W/A 60"					1	
	30253-06	Broiler Top W/A 72"						1
18	82011	Grate Broiler	3	5	7	10	12	15
19	82015	Lava Rock	1	2	3	4	5	6
20	82008	Waffle Grate Broiler	2	5	8	11	14	17
21	30254	Waffle Grate Support	1	2	3	4	5	6
22	30522	Burner Assembly		1	1	2	3	2
23	80029-02	Air Shutter H Burner	1	2	3	4	5	6
24	30255	Radiant Support Bracket	4	8	12	16	20	24
25	82007	Broiler Radiant	2	4	6	8	10	12
26	30242-01	Broiler Heat Shield 12"	1					
	30242-02	Broiler Heat Shield		2	3	4	5	6
27	30199-01	Center Drip Shield 48+				1	1	1
28	30200	Center Drip Shield Bracket				4	4	4

THERMA-TEK TERMS OF SALE AND ORIGINAL EQUIPMENT WARRANTY FOR INSTALLATION

The Therma-Tek Corporation warrants its new product (s) to be free from defects in material and workmanship for a period of one (1) year from the original date of purchase, not to exceed eighteen (18) months from shipment from the Factory to Dealer or Owner- User provided proof of purchase and installation date being provided to Therma-Tek Corporation prior to work being performed by an authorized Therma-Tek Service agency. This warranty shall be subject to the following conditions and limitations.

1. This warranty is limited to product (s) sold to the original commercial user.
2. The liability of Therma-Tek under this warranty is limited to, at Therma-Tek's option, the replacement or repair of any part found by Therma-Tek or an authorized service agency to not be as warranted herein, provided that written notice of defects shall be supplied to Therma-Tek within fifteen (15) days of its occurrence.
3. Therma-Tek shall bear normal labor and shipping charges incurred in such repair or replacement to the extent that such is performed within a fifty (50) miles from an office of an authorized service agency of Therma-Tek, except that such obligation to bear labor charges shall not apply to products or parts installed outside the continental United States. Should service be required at times which normally involve premium labor rates, the Owner-User shall be charged for the difference between normal service/shipping rates and such premium/shipping rates. All warranted parts will be shipped standard ground; anything other than ground will be at the expense of Owner-User.
4. Therma-Tek shall have no obligation as to any product (s) which have been misapplied, (including installation for residential use), mis-handled, damaged, abused, subjected to harsh chemical action or poor water quality, modified by an unauthorized service personnel, damaged by flood, fire or other acts of God or which have the serial number removed or altered. Failures caused by erratic voltages or gas supplies. Thermostats/ Safety Valves with broken capillary tubes.
5. Adjustments such as calibrations, air shutter adjustment and adjustments to pilots and burners, conversions, leveling, tightening of fasteners or utility connections, are the responsibility of the Owner-User (customer), Dealer or Certified Licensed installer and not that of Therma-Tek.
6. These warranty periods rather than one (1) year period herein provided for other parts shall apply for the product (s) listed.
 - a. Porcelain enamel and paint- 90days from purchase/ installation.
 - b. Rubber seals, door seals, chain mechanisms, light bulbs and gaskets- 90 days from purchase/ installation.
 - c. Cast-iron parts- 90 days from purchase/ installation.
 - d. Sight glass, spark ignitors, broiler briquettes, drip shields, baking decks and gas valves- 90 days from purchase/installation.
 - e. Mobile Food Truck/ Trailer- equipment will have 30 Days warranty after installation for any Therma-Tek product (s) installed on mobile kitchens; or used for Mobile Food Service.

All service issues need to be accompanied by proof of purchase and copy of certification from gas installer's receipt of compliance/ installation.

7. Therma-Tek Range Authorized Service Agencies under contract guarantee warranty work within thirty (30) days for replacement parts and/ or issues after installation and receipt of service rendered. Therma-Tek Range guarantees replacement parts and or service labor for ninety (90) days after service receipt for service work being performed by an Authorized Service Agency and unit being repaired and good working condition. Authorized Service Agency may require a credit card before entering premises for non-warranted issues.
8. This states the exclusive remedy against Therma-Tek relating to the product(s) whether in contract or in tort or under any other legal theory, and whether Arising out of warranties, representations, instructions, installations or defects from any cause.
9. This warranty and the liabilities set forth herein are exclusive and in lieu of all of their liabilities and warranties, expressed or implied, including but not limited to, implied warranties or merchantability and fitness for particular purpose and constitutes the only warranty of Therma-Tek with respect to the product (s).
10. Therma-Tek shall not be liable, whether in contract or in tort or under any other legal theory, for loss of use, revenue or profit, or for substitute use of performance, for incidental indirect, or special or consequential damages or for any other loss of cost of similar type.

WARRANTY REQUIREMENT

For reliable operation and for your own safety, this professional cooking equipment must be installed by a certified/ licensed contractor.

Failure to comply will void any written or implied warranty.

Should the equipment require service during the standard warranty period, the receipt proving certified installation

Must be made available to Therma-Tek Range for verification.

If installation was not performed by a certified/ licensed contractor, be prepared to submit a major credit card

For payment for proper installation prior to service.

TERMS AND CONDITIONS

Terms: Net 30 days subject to credit approval. All amounts past due are subject to 1.5% per month service charge will be applied to all invoices 30 days or more past due.

FOB: Factory

Prices: All prices are subject to change without notice. Prices do not include sales or any other local state tax.

Shipments: Shipments must be inspected for damaged cartons and shortages promptly noted upon receipt and also noted on delivery receipt. All shipments shall be inspected for hidden or concealed damage and noted and reported within ten (10) days to carriers and request an inspection at once.

Therma-Tek's responsibility for shipments ceases with acceptance by carriers and to Dealer or Owner-User. Once product is received free and clear; Therma-Tek is not responsible for any hidden or concealed damages for equipment or part(s). No claims for damaged or missing will be recognized unless written notice to Therma-Tek within ten (10) days of receipt. Therma-Tek is not responsible of repair of damaged goods created during transit, delivery and installation or created by acts of God.

Goods: Returned goods are subject to a 20% re-sticking charge and the cost of reconditioning. Return Authorization ("RA") number for all returns must be placed on label and shipped back to Therma-Tek. Merchandise without an RA number will not be accepted. All authorized returns must be sent freight pre-paid. All orders over sixty (60) days will not be accepted. Custom units built to buyer specifications may not be returned or cancelled.

Rush Shipments: Orders requiring next, 2nd or 3rd day priority shipments must be placed by 1:00 PM Eastern Standard Time. Rush shipment cannot be guaranteed.

Note: Since continuing product improvement is a Therma-Tek policy, the factory reserves the right to change specifications, designs and material without notice.