



# INSTALLATION AND OPERATING INSTRUCTIONS

MODELS: ST, PST, SST, PSST, ASST, APSST

## Steam Table

INTENDED FOR OTHER THAN HOUSEHOLD USE

RETAIN THIS MANUAL FOR FUTURE REFERENCE  
UNIT MUST BE KEPT CLEAR OF COMBUSTIBLES AT ALL TIMES

	<b>FOR YOUR SAFETY:</b> Do not store or use gasoline or other flammable vapors and liquids in the vicinity of this or any other appliance.	
--	--	--

	<b>WARNING:</b> Improper installation, adjustment, alteration, service or maintenance can cause property damage, injury or death. Read the Installation, Operating and Maintenance Instructions thoroughly before installing or servicing this equipment.	
--	---	--

Improper installation, adjustment, alteration, service or maintenance can cause property damage, injury or death. Read the Installation, Operating and Maintenance Instructions thoroughly before installing or servicing this equipment.

This equipment has been engineered to provide you with year-round dependable service when used according to the instructions in this manual and standard commercial kitchen practices.

Phone: +1 (214) 421-7366  
 Fax: +1 (214) 565-0976  
 Toll Free: +1 (800) 527-2100  
 Website: [www.apwwyott.com](http://www.apwwyott.com)  
 E-mail: [info@apwwyott.com](mailto:info@apwwyott.com)

**APWWYOTT**  
 729 Third Avenue  
 Dallas, TX 75226

## TABLE OF CONTENTS

### IMPORTANT FOR FUTURE REFERENCE

Please complete this information and retain this manual for the life of the equipment.  
For Warranty Service and/or Parts, this information is required.

\_\_\_\_\_

Model Number

\_\_\_\_\_

Serial Number

\_\_\_\_\_

Date Purchased

SECTION	ITEM	PAGE	SECTION	ITEM	PAGE
1	<a href="#">Owner's Information</a>	2	7	<a href="#">Cleaning</a>	8
2	<a href="#">Safety Information</a>	2	8	<a href="#">Troubleshooting</a>	9
3	<a href="#">Specifications</a>	3	9	<a href="#">Preventative Maintenance</a>	9
			10	<a href="#">Autofill Instructions</a>	
4	<a href="#">Installation Instructions</a>	4	11	<a href="#">Wiring Diagrams</a>	12
5	<a href="#">Operations Instructions for ST and PST</a>	5	12	<a href="#">Parts Lists &amp; Exploded Views</a>	14
6	<a href="#">Operations Instructions for SST AND PSST</a>	7	13	<a href="#">Warranty</a>	17



**WARNING:** In Europe, appliance must be connected by an earthing cable to all other units in the complete installation and thence to an independent earth connection in compliance with EN 60335-1 and/or local codes.



**WARNING:** An earthing cable must connect the appliance to all other units in the complete installation and from there to an independent earth connection.



## 1) OWNER'S INFORMATION

### General Information:

1. Always clean equipment thoroughly before first use. (See general cleaning instructions).
2. Check rating label for your model designation and electrical rating.
3. For best results, use stainless steel counter tops.

### General Operation Instructions:

14. All food-service equipment should be operated by trained personnel.
14. Do not allow your customers to come in contact with any surface labeled "CAUTION HOT".
14. Never pour cold water into dry heated units.
14. Do not cook, or hold food directly in wells. Always use steam table pans or inserts.
14. Never hold food below 150°F

### Warranty Information:

#### Reliability Backed By APW Wyott's Warranty:

All APW Wyott's Steam Tables are backed by a one year parts and labor warranty, including On-Site Service calls within 50 miles of authorized service technicians.

#### Service Information:

Service Hotline (800) 733-2203

## 2) SAFETY INFORMATION

APW Wyott equipment is designed, built, and sold for commercial use and should be operated by trained personnel only. Clearly post all CAUTIONS, WARNINGS and OPERATING INSTRUCTIONS near each unit to insure proper operation and to reduce the chance of personal injury and/or equipment damage. This product is used for the cooking, defrosting or re-thermalization of food products only.

Always disconnect power before servicing the unit. Surfaces will remain hot after power has been turned off. Allow unit to cool before cleaning or servicing. Never clean the unit by immersing it in water. The unit is not protected against water jets; DO NOT CLEAN THE STEAM TABLE WITH A WATER JET. Always clean equipment properly before first use.

### Safety Signs and Messages

The following Safety signs and messages are placed in this manual to provide instructions and identify specific areas where potential hazards exist and special precautions should be taken. Know and understand the meaning of these instructions, signs, and messages. Damage to the equipment, death or serious injury to you or other persons may result if these messages are not followed.

#### **DANGER**

This message indicates an imminently hazardous situation which, if not avoided, will result in death or serious injury.

#### **WARNING**

This message indicates a potentially hazardous situation, which, if not avoided, could result in death or serious injury.

#### **CAUTION**

This message indicates a potentially hazardous situation, which, if not avoided, may result in minor or moderate injury. It may also be used to alert against unsafe practices.

#### **NOTICE**

This message is used when special information, instructions or identification are required relating to procedures, equipment, tools, capacities and other special data.

## 3) SPECIFICATIONS: SST AND PSST

SST,PSST MODEL	VOLTS	WATTS	AMPS	PH
SST-2, PSST-2	120	1500	12.5	1
SST-3, PSST-3	120	2250	18.75	1
SST-4, PSST-4	120	3000	25	1
SST-5, PSST-5	120	3750	31.25	1
SST-2, PSST-2	208	1500	7.2	1
SST-3, PSST-3	208	2250	10.8	1
SST-4, PSST-4	208	3000	14.4	1
SST-5, PSST-5	208	3750	18.0	1
SST-2, PSST-2	240	1500	6.3	1
SST-3, PSST-3	240	2250	9.4	1
SST-4, PSST-4	240	3000	12.5	1
SST-5, PSST-5	240	3750	15.6	1

The Data plate is located on the right hand side bottom panel, where the power cord comes into the unit.

## SPECIFICATIONS: ST AND PST

SST,PSST MODEL	VOLTS	WATTS	AMPS	PH
ST-2, PST-2	120	1000	8.3	1



<b>ST-3, PST-3</b>	120	1500	12.5	1
<b>ST-4, PST-4</b>	120	2000	16.7	1
<b>ST-5, PST-5</b>	120	2500	20.8	1
<b>ST-2, PST-2</b>	208	1500	7.2	1
<b>ST-3, PST-3</b>	208	2250	10.8	1
<b>ST-4, PST-4</b>	208	3000	14.4	1
<b>ST-5, PST-5</b>	208	3750	18.0	1
<b>ST-2, PST-2</b>	240	1500	6.3	1
<b>ST-3, PST-3</b>	240	2250	9.4	1
<b>ST-4, PST-4</b>	240	3000	12.5	1
<b>ST-5, PST-5</b>	240	3750	15.6	1

**Power Cord:**

Six (6) foot, 3 wire grounded cord. If the supply cord is damaged, the manufacturer, or an authorized service agent, must replace it in order to avoid a hazard and warranty. Please contact the factory by calling the 800 # located on the unit.

**4) INSTALATION INSTRUCTIONS SST and PSST**

**If the carton appears damaged, or damage is discovered once the carton is opened, stop immediately and contact the freight company to file a damage claim.**

	<p><b>CAUTION:</b> The Steam Table is shipped without the legs, under shelf or cutting board shelf attached. Please read the installation and operation instruction before operating the unit. Remove all supports and packaging materials before operating the unit. Failure to remove all packaging materials may lead to a fire and / or damage to the appliance.</p>	
--	--	--

1. Remove all external packaging that is protecting top portion of unit
2. Remove all internal packaging to the unit, if present.
3. Visually inspect all external and internal portions of unit for damage.
4. Wipe down the exterior of the unit using a damp cloth with warm water. Do not use abrasive pads or cleaners as they will damage the stainless steel surface.

**Note:** Ambient Conditions - Make sure that the operating location is in an area where the ambient temperature is held constant (minimum 70°F). Please avoid areas such as near exhaust fans and air conditioning ducts.

**Warning!** Operating environment

Ensure that operation location is at a reasonable distance from combustible walls and materials otherwise combustion or discoloration could occur.

**Caution!** Operating environment

Place unit on a stable, level floor. The unit must be level, both front and back and left to right, in order to maintain an equal water depth throughout the wells. To eliminate rocking or adjust height turn the adjustable feet in the proper direction until the desired results are obtained.

**Note:** Maximum adjustment is 1 inch

5. A ¾ ball valve is supplied with every unit. The installer must provide a suitable drain connection. **This equipment is to be installed to comply with applicable federal, State or local plumbing codes.**
6. Before plugging unit into wall outlet or permanently electrical connecting, the unit should be adjusted to the desired height and align with other equipment.
7. The voltage and wattage ratings of this steam table are given on the device nameplate. Connect the steam table to a circuit having a voltage and type of current similar to that stamped on the device nameplate. For movable equipment a proper cord and plug are included for connection to the matching power supply outlet.

8. Plug unit into grounded electrical outlet with correct voltage, and plug configuration.
  - a. **Warning!** Using any receptacle that is not designed to match the attached cord and plug MAY cause personal injury and WILL void your warranty. Please attach the Steam Table, to an individual branch circuit
9. For permanent installations, connections to supply line may be made through conduit or armored cable. For supply connections use No. 12 AWG or larger wires suitable for at least 90°C (194°F). Use copper wire for power supply or suitable copper to aluminum wire connector.
10. The body of the appliance should be grounded by connecting the ground stud provided in the junction box to a good electrical ground, such as a water pipe, a steam pipe, or a grounded supply conduit.
11. The steam table is not fused and consequently must be connected to a fused circuit equipped with suitable disconnect means, as required by local code authorities.
12. To assemble the units follow steps 1 thru 6 listed below.
14. The bottom adjustable shelf assembly shall be installed such that there is a minimum clearance of 6 inches between the shelf and the supporting surface.
14. After the bottom adjustable shelf assembly is installed, the Allen screws shall be capped with the supplied plastic screw caps.

## NOTICE

**UNIT IS SHIPPED UNASSEMBLED. TO MEET NATIONAL SANITATION FOUNDATION STANDARDS, THE INSTALLER MUST USE A NSF APPROVED SILICONE SEALANT TO SEAL THE SEAMS BETWEEN THE UNIT AND ASSEMBLED PARTS**



### Step 1

**Insert the bullet leg into the 4 tubes. If the unit was supplied with caster skip this step and install caster before turning the unit over.**

### **CAUTION**

**When inserting bullet legs use a soft mallet only. To avoid damaging the leg inserts.**

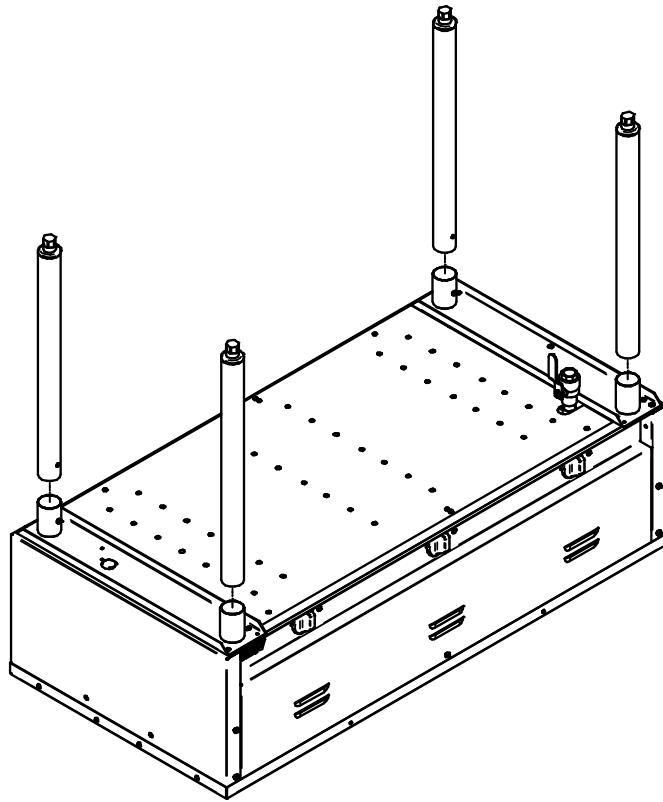

## Step 2

Place the unit on the floor upside down. Be sure to protect the top surface and well from damage when the unit is placed on it top on the floor. Once the legs are in place tighten the set screws in the leg inserts.

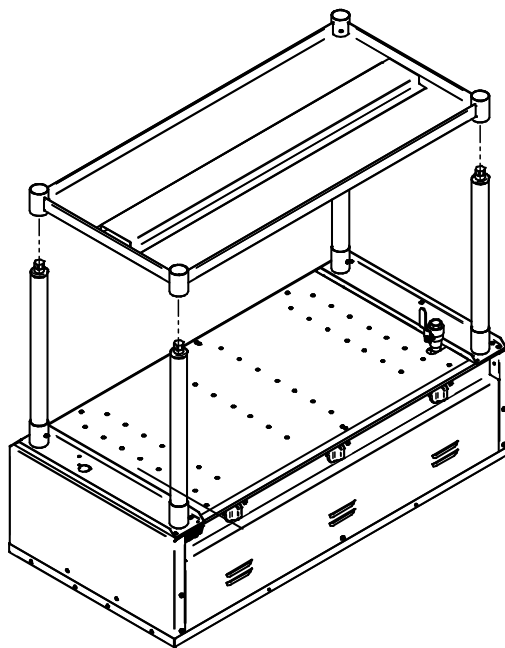

### Step 3

Slide the shelf over the legs.

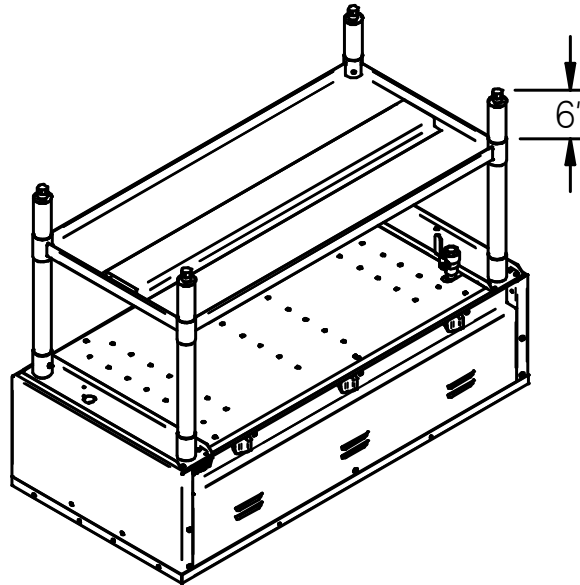

### Step 4

Locate the shelf at minimum 6 inches from the floor to allow for cleaning and to comply with NSF standards. Tighten the 4 set screws located in each corner of the shelf leg inserts.

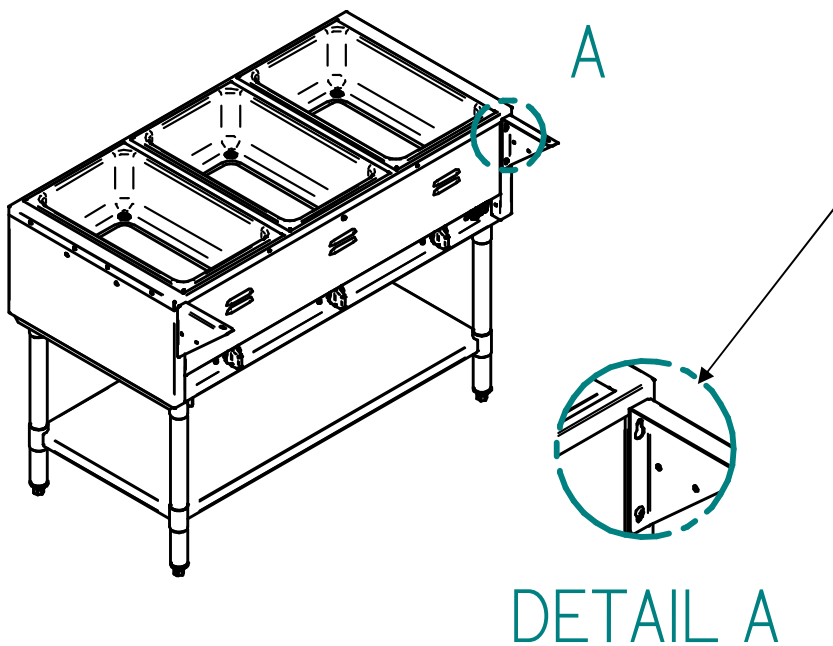

### Step 5

Install the shelf support brackets on each end. When positioning the bracket only put the bottom screw in place. Do not install the top screw until the shelf has been installed.

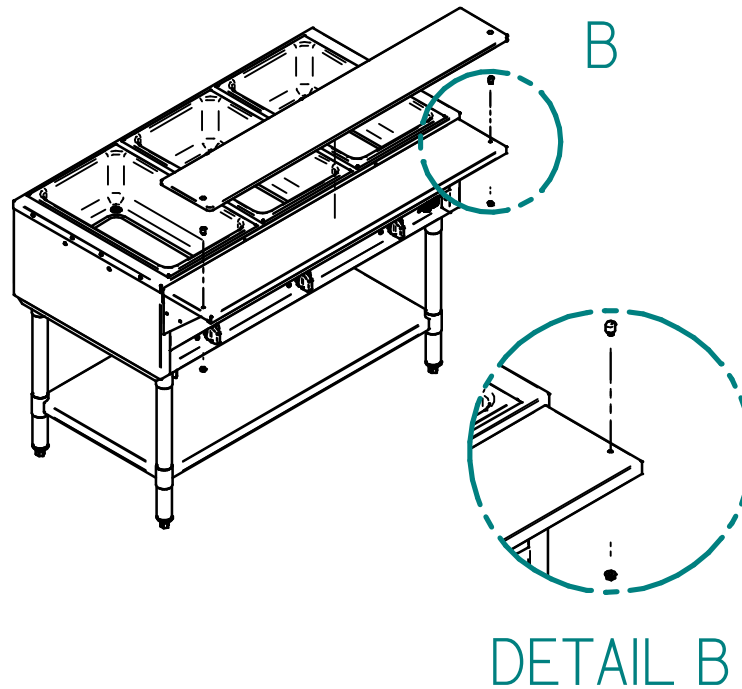

### Step 6

Place the shelf over the support brackets and install the top screw in each shelf bracket. Install the cut board stops through the shelf and the shelf support brackets at each end as shown.

## 5) OPERATION INSTRUCTION FOR ST AND PST

1. **PREHEAT** - To preheat individual sections, turn the switch dial to high for 10 - 20 minutes before the foods are placed in the compartments. Insure that pan openings are covered to prevent loss of heat.
2. **Water** – Is not necessary in the ST OR PST models.
  - a. **Note – If water is used the ST or PST models a spillage pan is required. When air is used the spillage is not required or recommended.**
  - b. Air. Being easier and quicker to heat than water makes the waterless steam table faster and more economical to operate than a table using water. Foods can be kept moist by keeping them at the correct temperature. Foods dry out only when excessive temperatures are reached, so when foods tend to dry out, REDUCE HEAT.
3. If only part of the food warmers is needed, the compartment not in use does not need to be heated.
4. **SWITCH SETTINGS**
  - a. The most satisfactory switch settings must be determined by experience based on the nature of the foodservice and the type of operation as well as individual preference of the restaurant operator. The proper switch setting necessary to keep foods at the desired temperature will vary dependent upon the frequency of turnover, size of food containers, amount of food in each container, room temperature, location of food warmer with respect to range or other heated equipment, air outlets, fans, doors and passageways.



## 6) OPERATION INSTRUCTION FOR SST AND PSST

1. Before the unit is used for the first time, turn the temperature knob to "10" and heat the well for 20-30 minutes. Do not be alarmed if smoke appears; this preheat should burn off any residue or dust on the heating element.

**WARNING: Steam can cause serious burns. Always wear some type of protective covering on your hands and arms when removing lids or pans from the unit. Lift the lid or pan in a way that will direct escaping steam away from your face and body.**

2. Never place food directly into the well. Always use pans.
3. Wet operation is recommended.
4. Always place covers on pans when not serving to prevent food from drying out and to reduce your operating costs.
5. For most efficient operation, keep empty, covered insets in each well during preheating and when the well is not in use.
  - a. **WET OPERATION**
    1. Fill food well with two (2) quarts of water. For quicker pre-heating, use hot water to fill the well.
    2. Turn the control to "HIGH" and pre-heat the warmer for 30 minutes.
    3. After pre-heating, set the control to your desired serving temperature.
    4. Never pour water into a well that has been heated dry. This may cause well to crack and leak.
    5. Always fill well before preheating or before water level is below 1/2".
  - b. **DRY OPERATION**
    1. Pre-heat the well on "HIGH" for approximately 15 minutes.
    2. After pre-heating, set the control to your desired serving temperature.

## 7) CLEANING

Insure the appliance has been turned off and has had sufficient time for all surfaces to cool down before cleaning.

**WARNING – Wooden cutting boards, Butcher Blocks, and Bakers Tables are not intended to be soaked for a prolonged length of time during the cleaning and sanitizing process.**

### DAILY CLEANING

1. Turn the control knob to the OFF position and allow unit to cool before cleaning.
2. Drain or remove water from the well.

**CAUTION: Do not allow water to splash or run on to the controls or wiring.**
3. Use a soft cloth or sponge with a mild detergent to clean the entire warmer assembly. Rinse completely with warm water and then dry.
4. A plastic scouring pad and a mild detergent may be used to remove hardened food.

**NOTICE: Do not use steel wool.**

### WEEKLY CLEANING

1. Scale deposits due to the mineral content of the water may be removed using a plastic scouring pad and a de-scaling agent approved for use on stainless steel. It is important to keep these deposits from building up as they may cause corrosion of the stainless steel well.
2. After de-scaling, the well assembly should be rinsed thoroughly with a solution of vinegar and water to neutralize all cleaner residues.
3. Wipe the well assembly dry and leave uncovered.

## WARNING

**Do not use any highly caustic cleaners, acids or ammonia. These may cause corrosion and/or damage to the stainless steel well. Do not allow water to stand in the well for long periods of time. Water must be removed from the well and the well cleaned after each use.**

## **CLEANING PROCEDURES FOR POLYETHYLENE OR ABS (RUBBER) COMPOSITION TABLE TOPS OR CUTTING BOARDS**

When high pressure cleaning equipment is not available; use hot water, a granular cleanser or detergent and a stiff bristle brush. (Abrasive action is necessary, as simply wiping the board will not suffice.) After Scrubbing, rinse thoroughly with hot water. Allow to lie flat.

Several excellent germicidal cleaners are also available, including Calgon's "Big Cat" and Johnson's "Break Up". Clorox is another good cleaner and is USDA approved.

The tabletop material is cut into sections not larger than 36" in any plane, and no section weighs more than fifty (50) pounds. These are stipulations of the National Sanitation Foundation to facilitate cleaning. The tops should be turned over daily to reduce possibility of warping and should never be stood on end. Periodically, go over the board with a clean, flat stainless steel scraper to help seal some of the knife marks.

The use of cleavers on synthetic boards or tabletops is not recommended.

## **8) TROUBLESHOOTING**

***Always ask and check the following:***

### **TROUBLE SHOOTING GUIDE**

1. Problem: Pilot light off and unit does not heat:
  - a. Has unit been connected to a proper electrical source of the proper voltage?
  - b. Is electric turned on at the main? Check the circuit breaker or fuse.
  - c. Are the master switch and/or control knobs set to the "ON" position?
2. Problem: Unit does not maintain proper food temperature.
  - a. Are the controls set to the proper setting?
  - b. If used with water, was hot water used to fill well? If not, allow extra pre-heat time.
  - c. Has unit been pre-heated for 30-45 minutes?
  - d. Were pans of food placed into unit at or above desired temperature?
  - e. Has the food been kept covered?
  - f. Are there air conditioning ducts, take-up air ducts or fans located near or over unit, causing cool drafts?
  - g. Has unit been connected to a proper electrical source of the proper voltage? If so, is there a "low" voltage condition?

## **9) PREVENTATIVE MAINTENANCE SCHEDULE**

- Please follow the cleaning section for the daily and weekly preventative maintenance schedule.
  1. Use the proper tools.
    - When cleaning stainless steel products, use non-abrasive tools. Soft cloths and plastic scouring pads will not harm steel's passive layer. Stainless steel pads also can be used but the scrubbing motion *must* be in the direction of the manufacturers' polishing marks.
  2. Clean with the polish lines
    - Some stainless steel comes with visible polishing lines or "grain." When visible lines are present, always scrub in a motion parallel to the lines. When the grain cannot be seen, play it safe and use a soft cloth or plastic scouring pad.

3. Use alkaline, alkaline chlorinated or non-chloride containing cleaners.
  - While many traditional cleaners are loaded with chlorides, the industry is providing an ever-increasing choice of non-chloride cleaners. If you are not sure of chloride content in the cleaner used, contact your cleaner supplier. If your present cleaner contains chlorides, ask your supplier if they have an alternative. Avoid cleaners containing quaternary salts; it also can attack stainless steel and cause pitting and rusting.
4. Treat your water.
  - Though this is not always practical, softening hard water can do much to reduce deposits. There are certain filters that can be installed to remove distasteful and corrosive elements. To insure proper water treatment, call a treatment specialist.
5. Keep your food equipment clean.
  - Use alkaline, alkaline chlorinated or non-chloride cleaners at recommended strength. Clean frequently to avoid build-up of hard, stubborn stains. If you boil water in stainless steel equipment, remember the single most likely cause of damage is chlorides in the water. Heating cleaners that contain chlorides have a similar effect.
6. Rinse.
  - If chlorinated cleaners are used, rinse and wipe equipment and supplies dry immediately. The sooner you wipe off standing water, especially when it contains cleaning agents, the better. After wiping equipment down, allow it to air dry; oxygen helps maintain the stainless steels passivity film.
7. Never use hydrochloric acid (muriatic acid) on stainless steel.
8. Regularly restore/passivate stainless steel.

## 10) Installation and Operation ASST and APSST Models

Installation instructions for EZ Well supply line:

- 1) Install PIN 54508, brass fitting in each end of the senoid using PTFE Tape (not supplied).
- 2) Wrap the threads of the fitting as shown below
- 3) Remove the nut from the brass fitting and the sleeve from the inside of the fitting
- 4) Place the seeve and the nut, nut first, over the W copper tubing, supplied.
- 5) Install the line into the solenoid and tighten the nut finger tight
- 6) Using a wrench, tighten the nut far enough to crush the sleeve and attach the line. NOTE Do not overtighten nut. Just enough pressure is required to stop water leaks
- 7) Install the 3/8 x 1/4 adapter to the 3/8 stainless steel tube fitting using PTFE Tape as shown.
- 8) Using the other end of the copper tube, install the line, nut, and sleeve to the adapter.
- 9) Tighten using the same procedure as before.
- 10) Turn on water supply and look for leaks. If any leaks are found, tighten the nuts until leak is stopped.

**INSTALLATION MUST BE DONE BY AUTHORIZED PLUMBER**

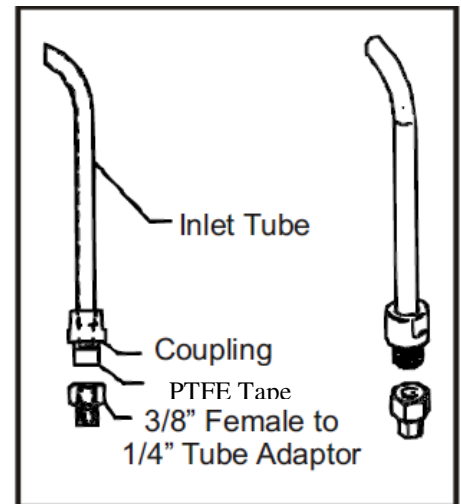
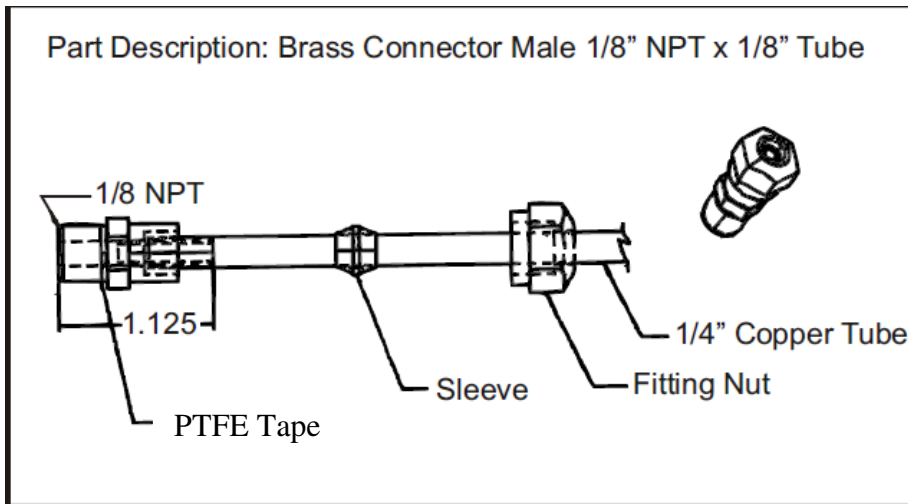

Operation:

Operation of the wells is the same as a SST/PSST steam table. To operate the auto fill, close ball valve and flip auto fill switch to the on position. The light next to the switch should light up indication that the auto fill is in operation.

# 11) WIRING DIAGRAMS/SCHEMATICS

## WIRING DIAGRAM – SST

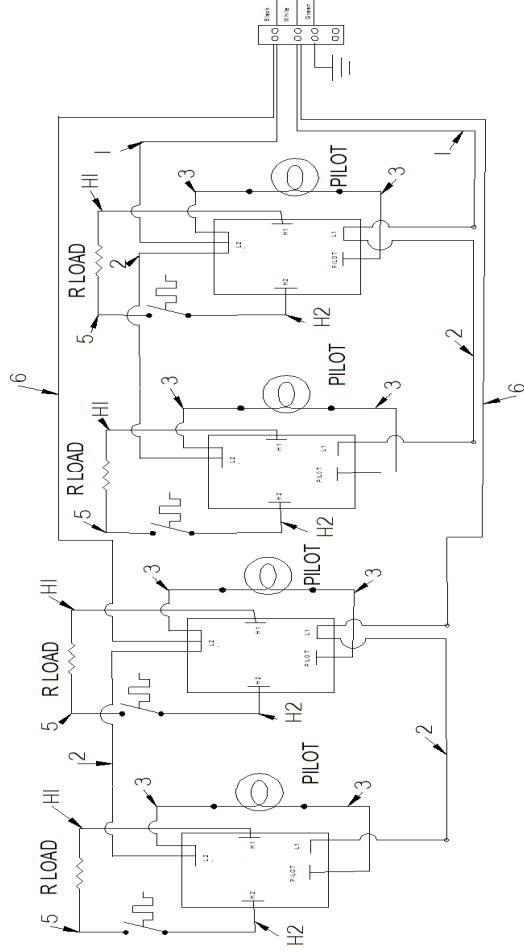

TWO WELL SINGLE PHASE  
SST

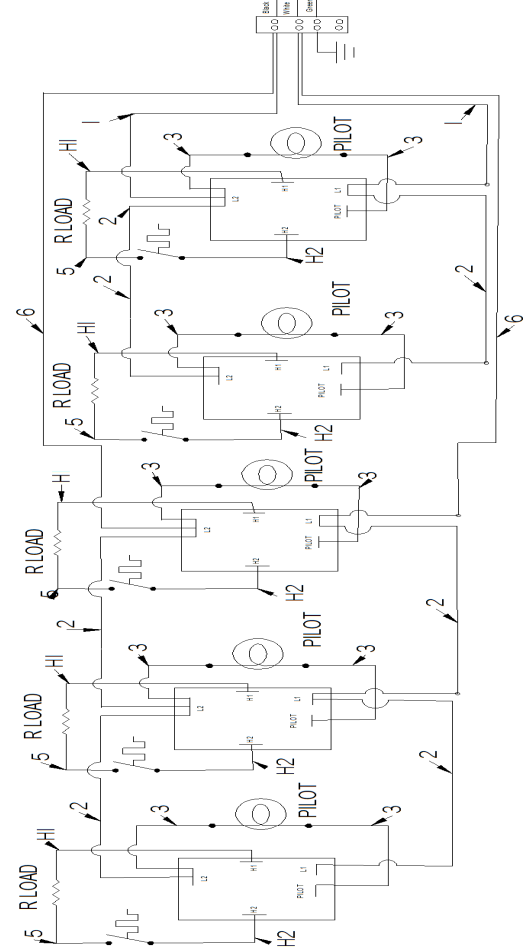

FOUR WELL SINGLE PHASE  
SST

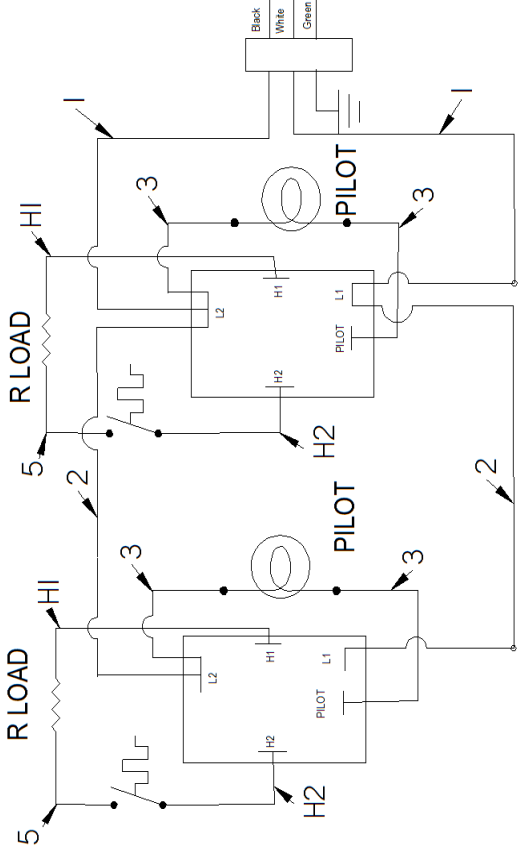

THREE WELL SINGLE PHASE  
SST

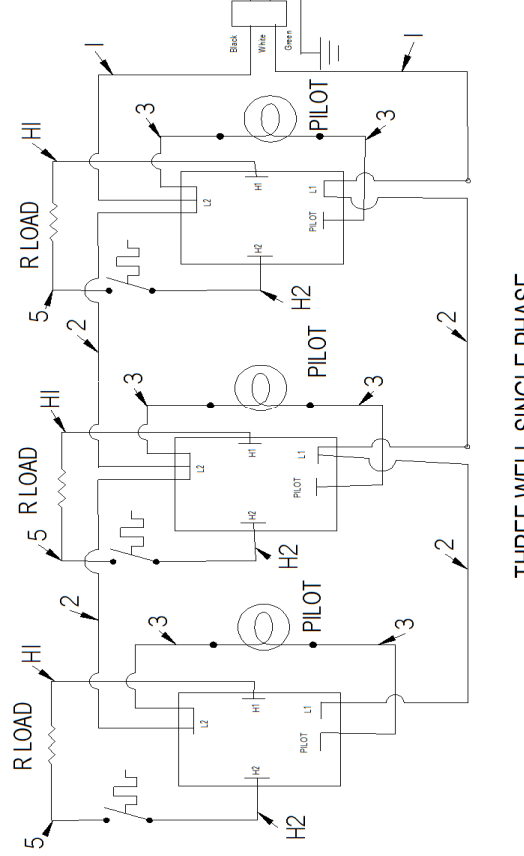

FIVE WELL SINGLE PHASE  
SST

# WIRING DIAGRAM —

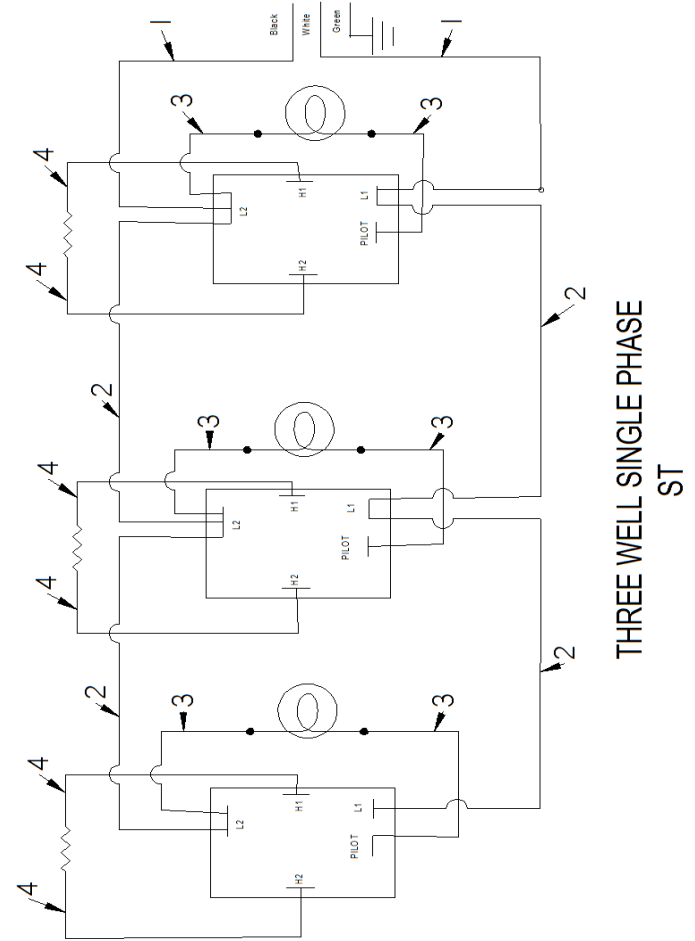
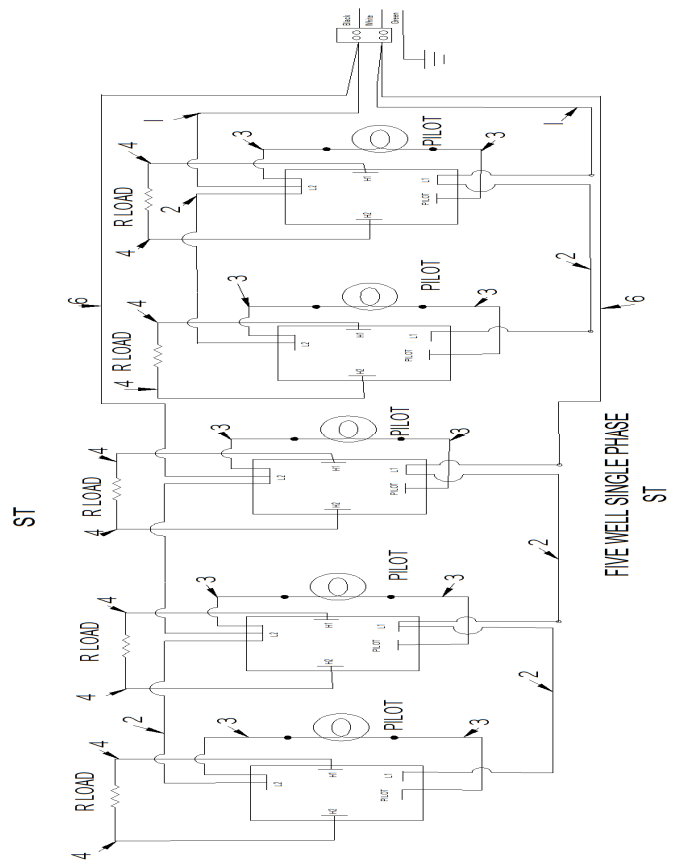
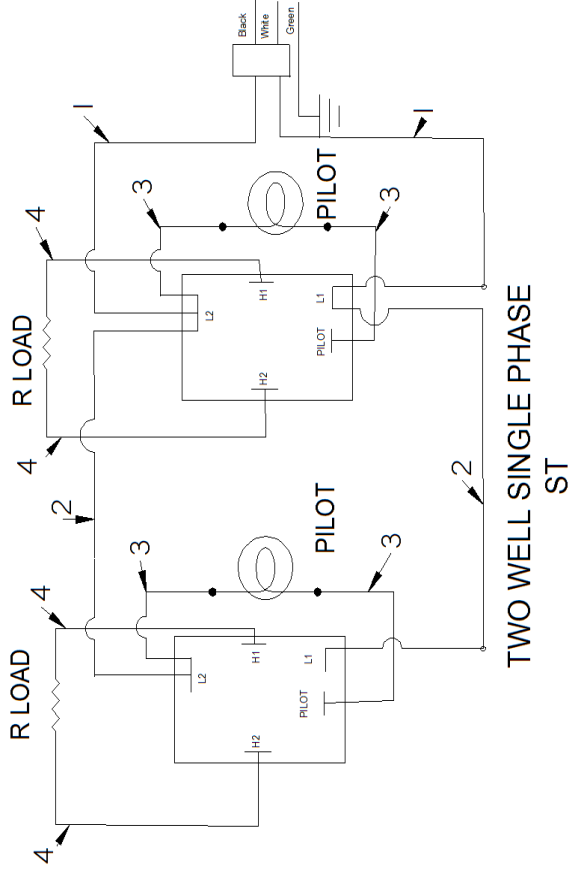
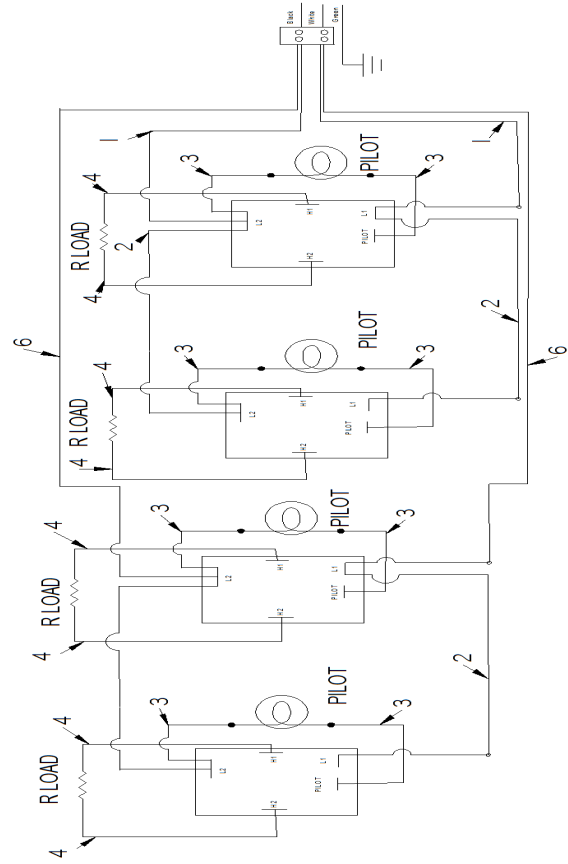

# Wirina Diagram ASST APSST

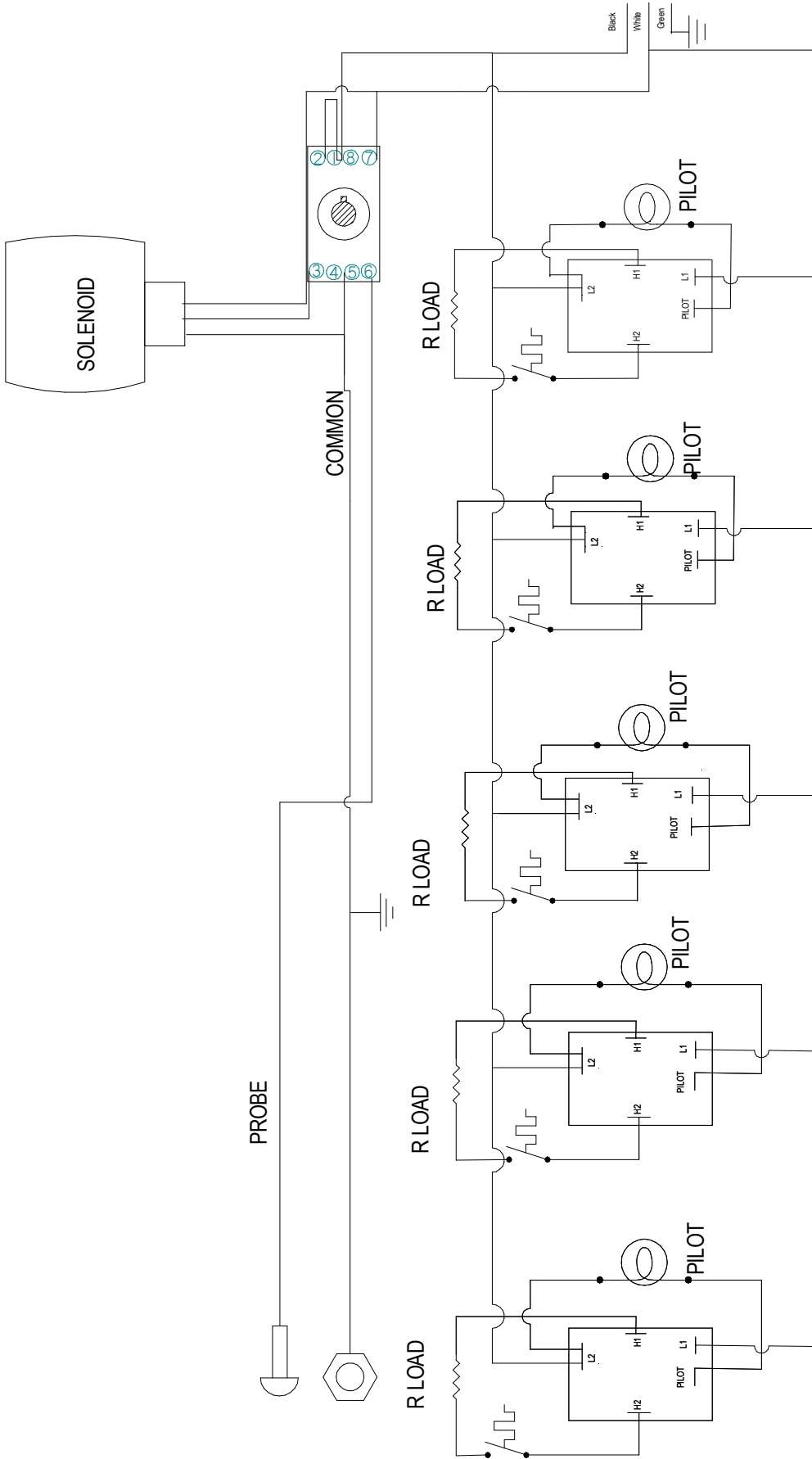

12) PARTS LISTS & EXPLODED VIEWS

ST-PST

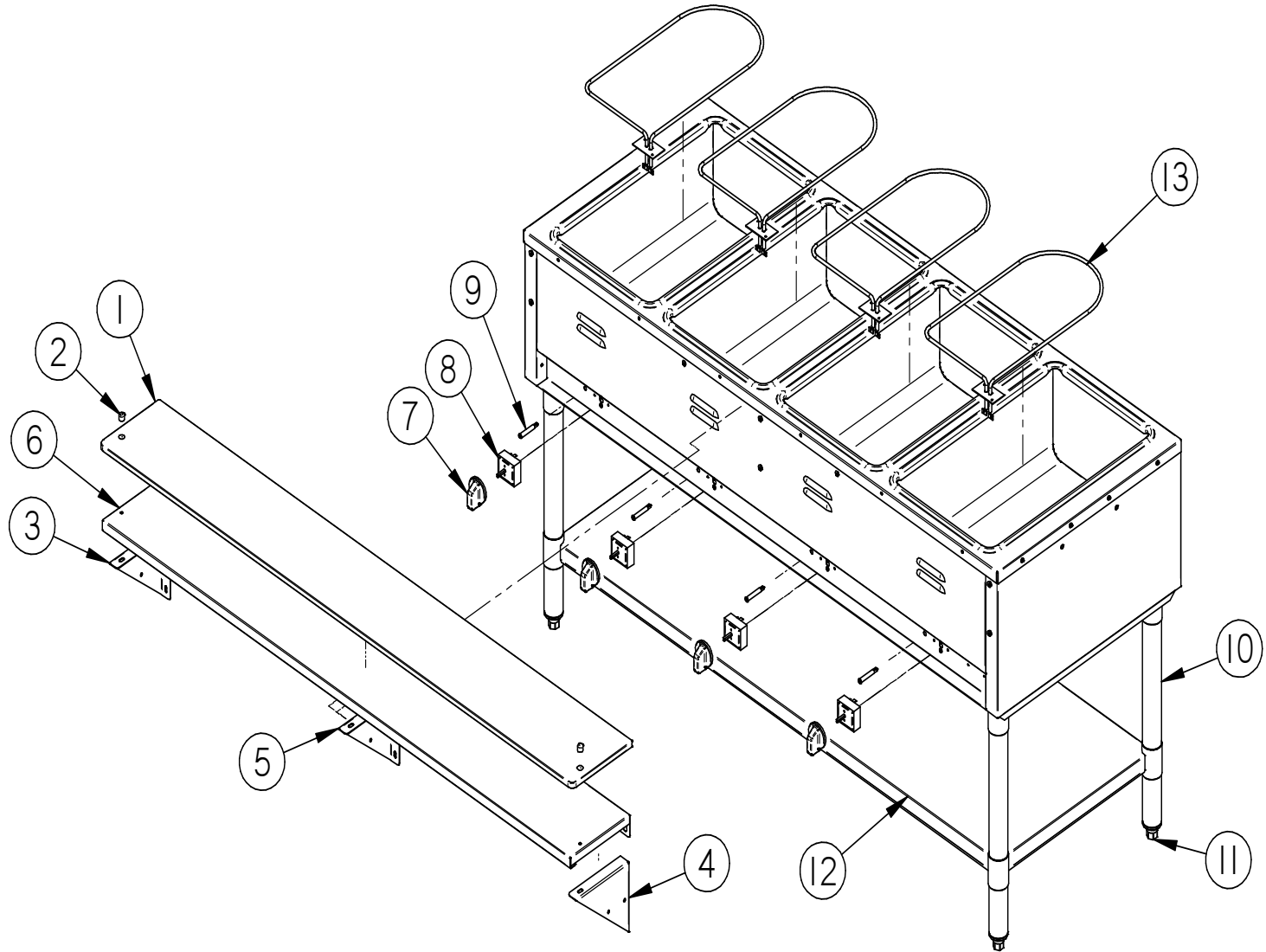



## PARTS LISTS & EXPLODED VIEWS

### Parts List ST-PST

Item #	Description	Part Number ST-2	Part Number ST-3	Part Number ST-4	Part Number ST-5
1	Poly Cutting Board	32010011	32010021	32010031	32010041
2	Stud Assembly	32010108	32010108	32010108	32010108
3	Bracket, Board Left	32010102	32010102	32010102	32010102
4	Bracket, Board Right	32010101	32010101	32010101	32010101
5	Bracket, Board Left	32010102	32010102	32010102	32010102
6	Support, Carving Board	32010016	32010026	32010036	32010046
7	Knob, 2"	8705610	8705610	8705610	8705610
8	Switch, Infinite 208-240V	1328200	1328200	1328200	1328200
8	Switch, Infinite 120V	1327900	1327900	1327900	1327900
9	Indicator Light	1513903	1513903	1513903	1513903
10	Leg, Galvanized for Caster	32010109	32010109	32010109	32010109
10	Leg, Stainless for Caster	32010097	32010097	32010097	32010097
10	Leg, Galvanized for Bullet Leg	32010008	32010008	32010008	32010008
10	Leg, Stainless for Bullet Leg	32010007	32010007	32010007	32010007
11	Caster with Brake	8671300	8671300	8671300	8671300
11	Caster without Brake	8671200	8671200	8671200	8671200
11	Bullet Leg	8656600	8656600	8656600	8656600
12	Adjustable Under shelf (Aluminized)	32010211	32010212	32010213	32010214
12	Adjustable Under shelf (Stainless)	32010111	32010112	32010113	32010114
13	Heater Element, 120V 500W	32010002	32010002	32010002	32010002
13	Heater Element, 208V 750W	32010003	32010003	32010003	32010003
13	Heater Element, 240V 750W	32010004	32010004	32010004	32010004

# PARTS LISTS & EXPLODED VIEWS

## SST-PSST

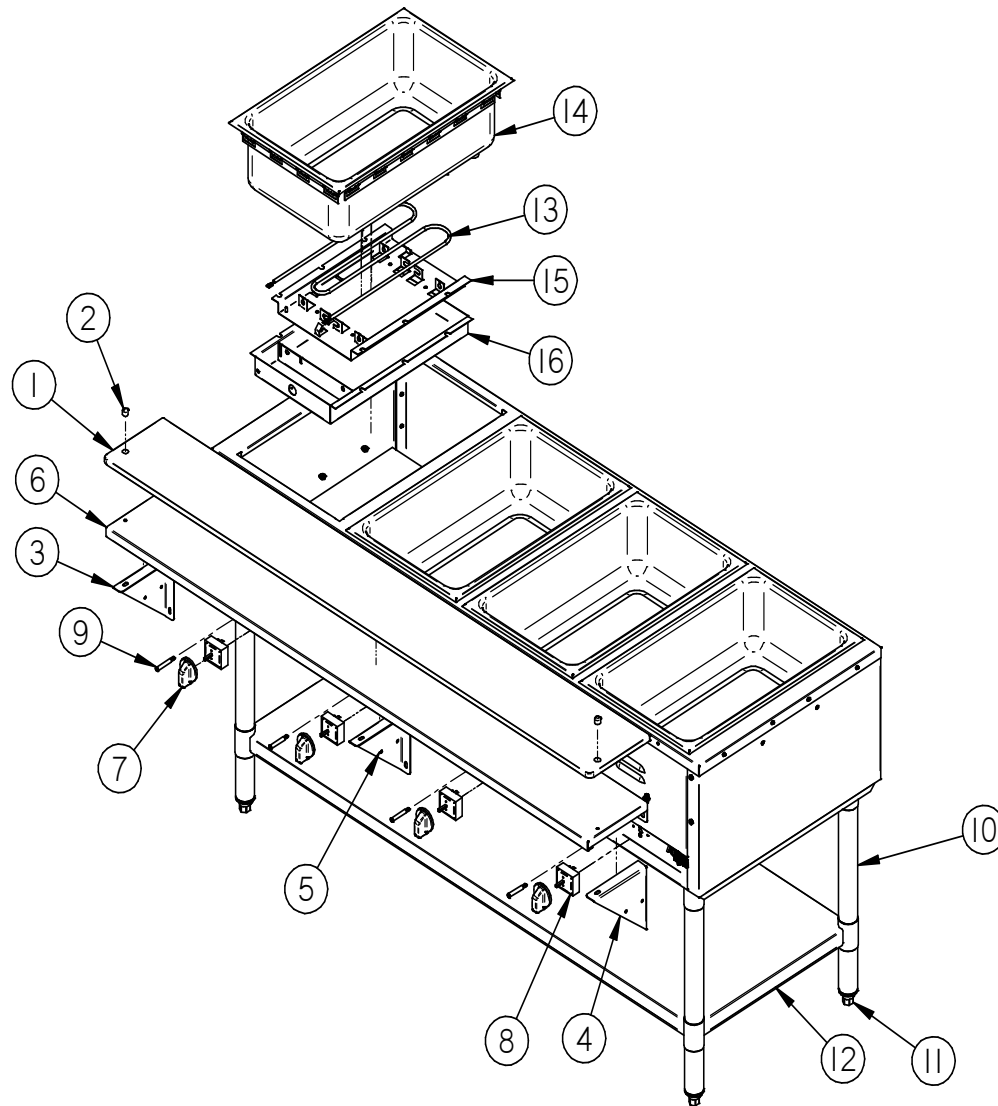

## PARTS LISTS & EXPLODED VIEWS

### SST-PSST Parts List

Item #	Description	Part Number SST-2	Part Number SST-3	Part Number SST-4	Part Number SST-5
1	Poly Cutting Board	32010051	32010061	32010071	32010081
2	Stud Assembly	32010108	32010108	32010108	32010108
3	Bracket, Board Left	32010102	32010102	32010102	32010102
4	Bracket, Board Right	32010101	32010101	32010101	32010101
5	Bracket, Board Left	32010102	32010102	32010102	32010102
6	Support, Carving Board	32010056	32010066	32010076	32010086
7	Knob, 2"	8705610	8705610	8705610	8705610
8	Switch, Infinite 208-240V	1328200	1328200	1328200	1328200
8	Switch, Infinite 120V	1327900	1327900	1327900	1327900
9	Indicator Light	1513903	1513903	1513903	1513903
10	Leg, Galvanized for Caster	32010109	32010109	32010109	32010109
10	Leg, Stainless for Caster	32010097	32010097	32010097	32010097
10	Leg, Galvanized for Bullet Leg	32010008	32010008	32010008	32010008
10	Leg, Stainless for Bullet Leg	32010007	32010007	32010007	32010007
11	Caster with Brake	8671300	8671300	8671300	8671300
11	Caster without Brake	8671200	8671200	8671200	8671200
11	Bullet Leg	8656600	8656600	8656600	8656600
12	Adjustable Under shelf (Aluminized)	32010215	32010216	32010217	32010218
12	Adjustable Under shelf (Stainless)	32010115	32010116	32010117	32010118
13	Heater Element, 120V 500W	55445	55445	55445	55445
13	Heater Element, 120V 1200W	55446	55446	55446	55446
13	Heater Element, 208V 750W	45547800	45547800	45547800	45547800
13	Heater Element, 208V 1200W	55441	55441	55441	55441
13	Heater Element, 240V 750W	45547700	45547700	45547700	45547700
13	Heater Element, 240V 1600W	55441	55441	55441	55441
14	WELL PAN W/DR	55607	55607	55607	55607
15	REFLECTOR, PLATE WELD ASSY	55567	55567	55567	55567
16	BOTTOM COVER ASSY	55608	55608	55608	55608
Not shown	THERMOSTAT, LIMITING	69106	69106	69106	69106

***NOTES:***

---

---

---

---

---

---

---

---

---

---

---

---

---

---

---

---

---

---

---

---

---

---

---

---

---

### 13. APW WYOTT EQUIPMENT LIMITED WARRANTY

APW Wyott Food service Equipment Company warrants its equipment against defects in materials and workmanship, subject to the following conditions:

This warranty applies to the original owner only and is not assignable.

Should any product fail to function in its intended manner under normal use within the limits defined in this warranty, at the option of APW Wyott such product will be repaired or replaced by APW Wyott or its Authorized Service Agency. APW Wyott will only be responsible for charges incurred or service performed by its Authorized Service Agencies. The use of other than APW Wyott Authorized Service Agencies will void this warranty and APW Wyott will not be responsible for such work or any charges associated with same. The closest APW Wyott Authorized Service Agent must be used.

This warranty covers products shipped into the 48 contiguous United States, Hawaii, metropolitan areas of Alaska and Canada. There will be no labor coverage for equipment located on any island not connected by roadway to the mainland.

Warranty coverage on products used outside the 48 contiguous United States, Hawaii, and metropolitan areas of Alaska and Canada may vary. Contact the international APW Wyott distributor, dealer, or service agency for details.

#### Time Period

One year for parts and one year for labor, effective from the date of purchase by the original owner. The Authorized Service Agency may, at their option, require proof of purchase. Parts replaced under this warranty are warranted for the un-expired portion of the original product warranty only.

#### Exceptions

- \* **Gas/Electric Cookline:** Models HCB, HCRB, HMG, HTG, HHP, HHPS, GCB, GCRB, GF, GGM, GGT, CHP-H, EF, EG, EHP. Three (3) Year Warranty on all component parts, except switches and thermostats. (2 additional years on parts only. No labor on second or third year.)
- \* **Broiler Briquettes, Rock Grates, Cooking Grates, Burner Shields, Fireboxes:** 90 Day Material Only. No Labor.
- \* **Heat Strips:** Models FD, FDL, FDD, FDDL. Two (2) Year Warranty on element only. No labor second year.
- \* **Glass Windows, Doors, Seals, Rubber Seals, Light Bulbs:** 90 Day Material Only. No Labor.

In all cases, parts covered by extended warranty will be shipped FOB the factory after the first year.

#### Portable Carry In Products

Equipment weighing over 70 pounds or permanently installed will be serviced on-site as per the terms of this warranty. Equipment weighing 70 pounds or under, and which is not permanently installed, i.e. with cord and plug, is considered portable and is subject to the following warranty handling limitations. If portable equipment fails to operate in its intended manner on the first day of connection, or use, at APW Wyott's option or its Authorized Service Agency, it will be serviced on site or replaced.

From day two through the conclusion of this warranty period, portable units must be taken to or sent prepaid to the APW Wyott Authorized Service Agency for in-warranty repairs. No mileage or travel charges are allowed on portable units after the first day of use. If the customer wants on-site service, they may receive same by paying the travel and mileage charges. Exceptions to this rule: (1) countertop warmers and cookers, which are covered under the Enhanced Warranty Program, and (2) toasters or rollergrills which have in store service.

#### Exclusions

The following conditions are not covered by warranty:

- \* Equipment failure relating to improper installation, improper utility connection or supply and problems due to ventilation.
- \* Equipment that has not been properly maintained, calibration of controls, adjustments, damage from improper cleaning and water damage to controls.
- \* Equipment that has not been used in an appropriate manner, or has been subject to misuse or misapplication, neglect, abuse, accident, alteration, negligence, damage during transit, delivery or installation, fire, flood, riot or act of god.
- \* Equipment that has the model number or serial number removed or altered.

If the equipment has been changed, altered, modified or repaired by other than an Authorized Service Agency during or after the warranty period, then the manufacturer shall not be liable for any damages to any person or to any property, which may result from the use of the equipment thereafter.

This warranty does not cover services performed at overtime or premium labor rates. Should service be required at times which normally involve overtime or premium labor rates, the owner shall be charged for the difference between normal service rates and such premium rates. APW Wyott does not assume any liability for extended delays in replacing or repairing any items beyond its control.

In all cases, the use of other than APW Wyott Authorized OEM Replacement Parts will void this warranty.

This equipment is intended for commercial use only. Warranty is void if equipment is installed in other than commercial application.

#### Water Quality Requirements

Water supply intended for a unit that has in excess of 3.0 grains of hardness per gallon (GPG) must be treated or softened before being used. Water containing over 3.0 GPG will decrease the efficiency and reduce the operation life of the unit.

**Note: Product failure caused by liming or sediment buildup is not covered under warranty.**

**"THE FOREGOING WARRANTY IS IN LIEU OF ANY AND ALL OTHER WARRANTIES EXPRESSED OR IMPLIED INCLUDING ANY IMPLIED WARRANTY OF MERCHANTABILITY OR FITNESS FOR PARTICULAR PURPOSES AND CONSTITUTES THE ENTIRE LIABILITY OF APW WYOTT. IN NO EVENT DOES THE LIMITED WARRANTY EXTEND BEYOND THE TERMS STATED HEREIN."**

9/05