

COUNTER TOP ELECTRIC PIZZA & BAKE OVENS



Model DP-2
with optional top & bottom heat controls

Specifications

- The DP-2 electric counter top oven feature two independent, operator controlled baking chambers with 5 1/2" (140mm) deck heights and hearth stone decks making them ideal for baking, roasting or pizza. Perfect for pan pizza.
- The DP-2 features two sets of controls – one set for each bake chamber. Each set consists of a 15-minute electric timer with continuous ring audible alarms and manual shut-offs, ready-on oven indicator light.
- The exterior front, sides, top and door are fabricated of heavy gauge type 430 stainless steel with a #4 finish. Door handle is constructed of tubular stainless steel. Exteriors measures 26" wide (660mm) by 28" deep (711mm) by 24" tall (610mm) overall.
- The interiors are constructed of high heat aluminized steel, welded to form a single unitized body. The entire oven is insulated with 1 1/2" thick (38mm) industrial grade insulation. Each hearth stone deck measures 20 3/4" (527mm) by 20 3/4" (527mm) by 1/2" thick (13mm).
- Incoloy, tubular heating elements provide top and bottom heat with up to 5050 watts in 208 or 220/240V, single or three phase. Ovens are stackable
- Brick lining increases top heat intensity and speeds recovery.

Standard Features

- DP-2 at 5050 watts in 208V or 220/240V"
- Two independent, operator controlled cook/bake chambers each with a separate set of controls
- Two 15-minute electric timers with continuous ring, audible alarms and manual shut-offs (one for each chamber)
- 300°-650°F (149°-343°C) Thermostats (one for each chamber).
- Hearth stone decks.
- 5 1/2" Deck height (140mm).
- All stainless steel exterior
- Unitized, welded, aluminized steel interior
- Fully insulated
- 4" (102mm) adjustable legs
- Interior lights
- Limited one year parts & labor warranty

Options & Accessories

- Stainless Steel Stand with or without casters
- Stacking kit
- Steel decks in lieu of hearth stone
- International voltages
- Infinite controls for independent top & bottom heat control
- Brick lined

Certifications



COUNTER TOP ELECTRIC PIZZA & BAKE OVENS

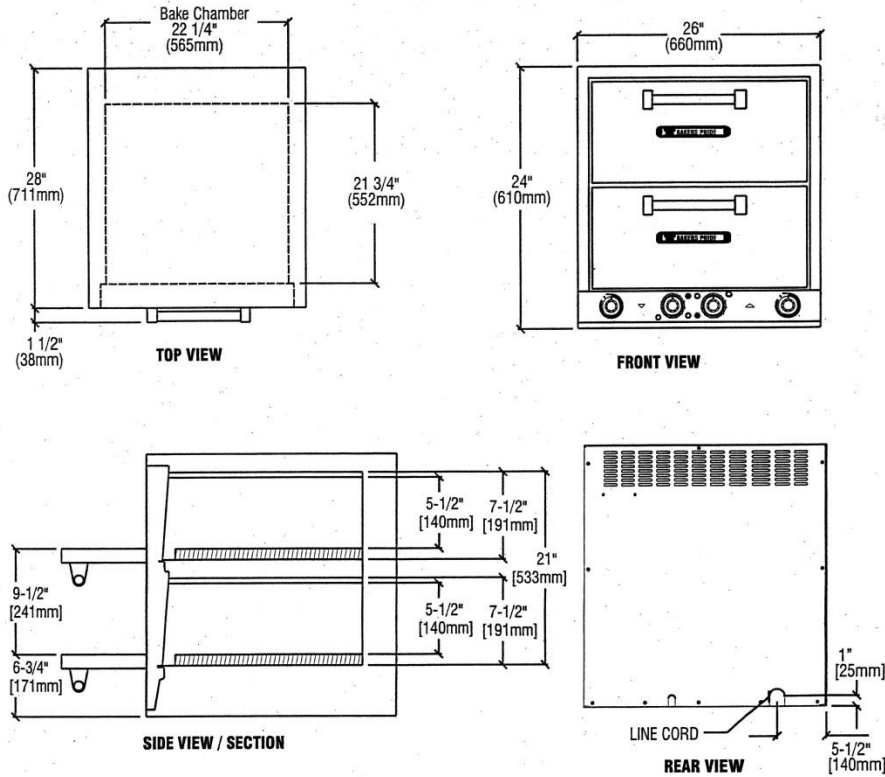

Electrical Specifications		
Voltage (US) 60 HZ (Optional 200/220/230V 50 HZ)	208	220/240
Watts	5050	5050
Amperage	24.5 & 14	22 & 12.7
Phase	1 or 3	1 or 3
Plug configuration NEMA (domestic US)	6-30P	6-30P
Exterior Dimensions		
Height	24	24
Width	26	26
Depth	28	28
Cook Chamber Dimensions		
Height	21 3/4	21 3/4
Width	20 3/4	20 3/4
Depth	20 3/4	20 3/4
Weight lbs.	260	270
Stackable	Yes	Yes
Clearances (inches)	0	0
Sides	1	1