



CONVECTION FLO SERIES GAS DECK OVENS



Job _____ Item # _____

GAS DECK OVENS



Model 451
with optional casters

Single	Double	Triple
251	252	253
351	352	353
451	452	453

STANDARD FEATURES

- 60,000 to 80,000 BTUH per deck, natural or LP gas (LP not CE approved)
- 300°-650° F (149°-343°C) throttling thermostat
- Top & bottom heat control damper
- Combination gas controls with valve, regulator & pilot safety
- Heavy-duty, slide-out flame diverters
- 8" (203mm) interior deck heights with 1 1/2" (38mm) thick Cordierite hearth decks
- All stainless steel exteriors
- Aluminized steel interiors
- Spring balanced, fully insulated doors
- Side or rear gas connections
- 7-Gauge legs
- Fully insulated throughout
- 1 Year limited part and labor warranty

SPECIFICATIONS

BAKERS PRIDE Convection Flo Series gas Deck Ovens are designed for high volume pizza and all-purpose operations.

Ovens may be stacked three high. Oven exteriors are all heavy-gauge, type 403 stainless steel and are fully insulated for cooler outer temperatures and consistent interior temperatures.

Interior oven frame is constructed of 1/4" (6mm) heavy-duty angle iron frame, completely welded to form a single, unitized section. The oven body and lining are then welded to the framework.

Oven interiors are manufactured of high-heat resistant 16-gauge aluminized steel. Doors are fully insulated, spring balanced with tubular steel handles and will remain open or closed until moved.

All models feature independent, operator-controlled top & bottom heat control damper.

Convection Flo Series features a 300°-650° F (149°-343°C) throttling thermostat, 8" (203mm) interior deck height with 1 1/2" (38mm) thick Cordierite hearth decks (steel decks optional) and are supported by a 1/4" (6mm) angle iron frame.

Combination gas control incorporates a manual gas valve, pilot safety and pressure regulator. Easily removable, slide-out, heavy-duty flame diverters distribute the burner flame uniformly in the burner chamber. A 3/4" (19mm) NPT gas connection is located on the left side and left rear of oven - operator/installer may choose.

Heavy-duty, 7-gauge hot rolled steel legs are standard and finished with durable Bakertone.

1 Year limited parts and labor warranty standard.

OPTIONS & ACCESSORIES

- Steel decks
- 150°-550° F (65°-288°C) thermostat
- Set of 4 casters - two with locks
- Stainless steel leg covers
- Special height legs
- Steam Injection
- Automatic oven starter
- Draft flue for direct vent (not available on CE units)

CERTIFICATIONS



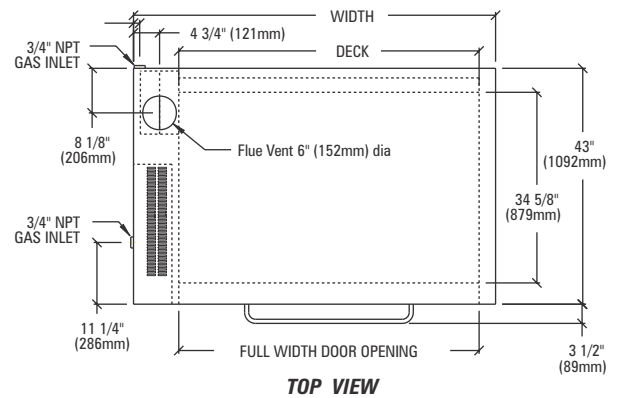
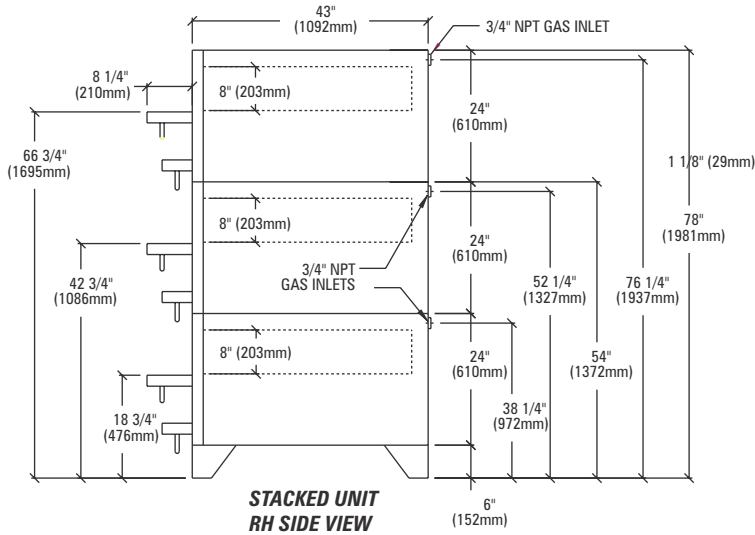
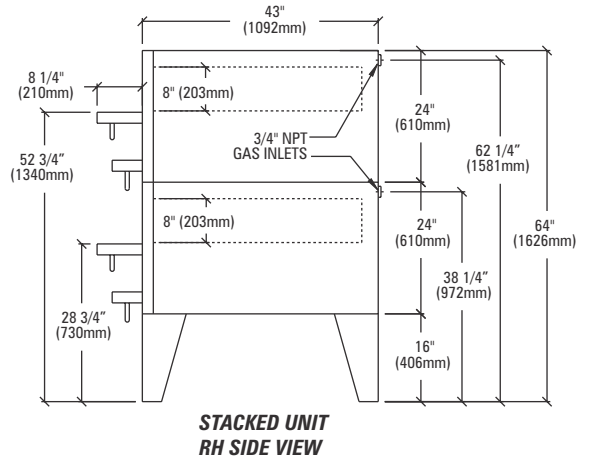
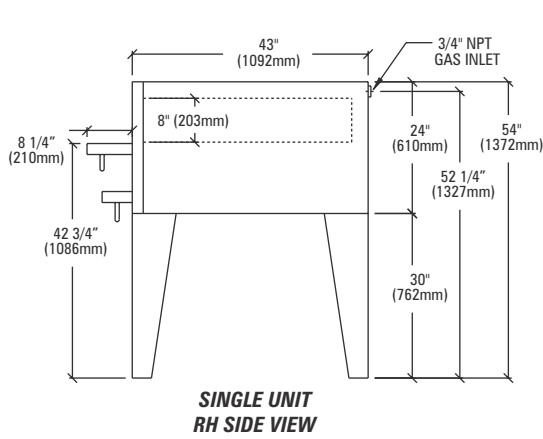

ALL DIMENSIONS NOMINAL

Model	Shipping Weight		Carton Dimensions				Crate Size			
	Lbs.	Kilos	Width Inches	mm	Depth Inches	mm	Height Inches	mm	Cubic Feet	Cubic Meter
251	820	372	53	1346	40	1016	37	940	44.4	1.4
351	958	434	52	1321	36	914	72	1829	76.2	2.7
451	1093	496	52	1321	36	914	72	1829	76.2	2.7

Shipping Class # 70
Each oven ships separately
Hearth decks & legs ship in separate cartons

Model	Deck Size				# Decks	Overall Dimensions					
	Inches	mm	Height Inches	mm		Width Inches	mm	Depth Inches	mm	*Height Inches	mm
251	36x34 1/2	914x876	8	203	1	48	1219	43	1092	54	1372
252	36x34 1/2	914x876	8	203	2	48	1219	43	1092	64	1626
253	36x34 1/2	914x876	8	203	3	48	1219	43	1092	78	1981
351	45x34 1/2	1143x876	8	203	1	57	1448	43	1092	54	1372
352	45x34 1/2	1143x876	8	203	2	57	1448	43	1092	64	1626
353	45x34 1/2	1143x876	8	203	3	57	1448	43	1092	78	1981
451	54x34 1/2	1372x876	8	203	1	66	1676	43	1092	54	1372
452	54x34 1/2	1372x876	8	203	2	66	1676	43	1092	64	1626
453	54x34 1/2	1372x876	8	203	3	66	1676	43	1092	78	1981

* Height includes 30" (762 mm) standard legs on models 151,3151,4151
** Height includes 16" (406 mm) standard legs on models 152,3152,4152
* Height includes 6" (152 mm) standard legs on models 153,3153,4153
CE approved units may only be stacked two high

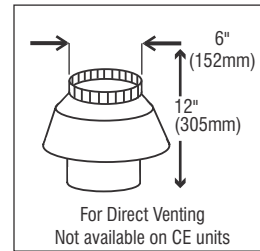

MUST BE SPECIFIED AT TIME OF ORDER

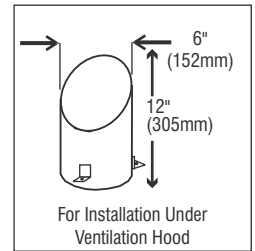

STANDARD

Model	BTUH	KW	CONNECTION
251	60,000	18	3/4"
351	70,000	21	3/4"
451	80,000	24	3/4"

Each oven requires separate gas connection
CE certification not available in LP gas

MINIMUM CLEARANCES

	Non-Combustible Construction*		Combustible Construction**	
	Inches	mm	Inches	mm
Left Side	0	0	1	25
Right Side	0	0	3	76
Rear	2	51	3	76

* In European Community Countries and North America. In NON-COMBUSTIBLE locations only.
** In European Community Countries only in COMBUSTIBLE locations. NOT for North America.

