

THERMA-TEK

R A N G E C O R P .

Therma-Tek Range Corp.
115 Rotary Drive, Valmont Industrial Park
West Hazleton, PA 18202



TFCO-GM-1

(shown with optional casters)

NOTE: Oven supplied with casters must be installed with an approved restraining device.

FULL SIZE GAS CONVECTION OVEN

STANDARD FEATURES

- * 60,000 BTU's/hr direct fired burner - Natural Gas (54,000BTUs Propane Gas).
- * Unique air delivery system through a double walled baffle system allows for a very even bake on all rack positions.
- * Flue venting system is internal with no unsightly exterior boxes.
- * Fully enclosed oven back panel.
- * Unique design makes for a highly efficient oven that utilizes the maximum amount of usable heat before exuding out of the flue system.
- * Single oven door eliminates cumbersome and inefficient door chains and inherent leaks between doors.
- * Fully sealed oven cavity with positive door closure.
- * Heavy-duty refrigerator latch mechanism for a positive door closure.
- * Large front accessible and serviceable control area keeps controls cool, reducing oven failure.
- * Six chrome plated racks; with 12 rack positions.
- * Side rack slides, racks and baffles are easily removable for cleaning.
- * The unique single door design does not require any more aisle space than competitor double-door models.
- * Electro-mechanical control with snap-action thermostat 150°F to 500°F (65.6°C to 260°C).
- * Electronic control with "cook-n-hold" feature available 2009.
- * Gas pressure regulator.
- * Single door opens past 180 degrees.
- * Full welded angle iron construction for a structurally sound oven bottom.
- * Legs mounted to angle iron frame of main bottom.
- * Stainless steel front, sides, top, legs, shelf (single deck only).
- * Stainless steel bottom shelf comes standard with single deck oven.
- * Double stack kit comes standard with double stack unit.
- * No exposed screws provides a sleek design; making exterior wipe down and cleaning safe and easy.
- * ½ hp, 2-speed motor.

OPTIONAL FEATURES

- * Single deck leg kit w/Bottom Shelf (required for single unit).
- * Extra Oven Rack.
- * Oven rack slides (two).
- * Double Stack Kit with short legs (required for double stack unit).
- * Stainless steel exterior back.
- * Stainless steel interior.
- * Single deck casters (2 locking, 2 non-locking).
- * Double stack unit casters (2 locking, 2 non-locking).
- * Gas flex hose w/ quick disconnect and restraining device.



Therma-Tek Range Corp.
115 Rotary Drive, Valmont Industrial Park
West Hazleton, PA 18202

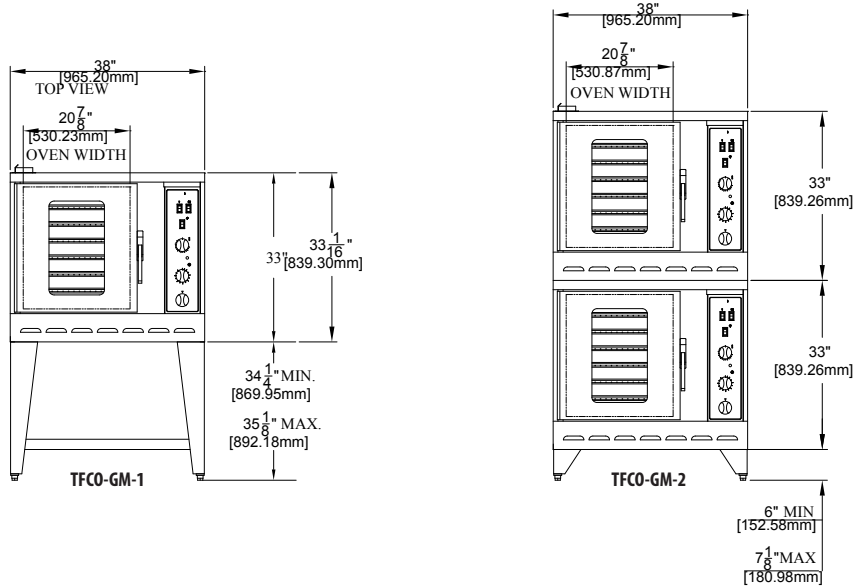

GAS REQUIREMENTS					
Operating Manifold Gas Pressure					
Natural		Propane		Manifold Connection	Input Rating per Deck
"WC	mbar	"WC	mbar		
5	12.45	10	24.9	3/4" NPT	Total BTU/Hr 60,000 kW 17.59

ELECTRICAL REQUIREMENTS
120V / 1PH. 6.4 amps per oven

Model Number	Description	Total gas consumption per model		Gross Weight	
		Total BTU/Hr	kW	Lbs.	Kg
TFCO-GM-1	Single Deck Full Size Convection Oven, Electro-mechanical Controls	60,000	17.59	635	288.30
TFCO-GM-2	Double Deck Full Size Convection Oven, Electro-mechanical Controls	120,000	35.18	1270	576.60
TFCO-GE-1*	Single Deck Full Size Convection Oven, Electronic Controls	60,000	17.59	635	288.30
TFCO-GE-2*	Single Deck Full Size Convection Oven, Electronic Controls	120,000	35.18	1270	576.60

* Available in 2009

NOTE: Add suffix "N" for natural gas, and "L" for propane.

CLEARANCES	Sides		Back
	Left	Right	
Non Combustible	0"	2" (50.8mm)	0"
Combustible	2" (50.8mm)	2" (50.8mm)	1" (25.4mm)

Crated Dimensions			
Width	Depth	Height	Cubic Feet
45" (1,143mm)	45" (1,143mm)	49" (1,245mm)	57.4

Installation Notes

This product is NOT approved for residential use.
 Please advise us of installation over 2000ft. (610m) altitude.
 Installation clearance reduction applies only where local codes permit.
 All Therma-Tek products are covered by a one year limited parts and labor warranty.
 A detailed warranty is included with the appliance or is available upon request.
 Installation and/or operation by other than manufacturer's recommendations may void warranty.
 Because of continuing product improvement, these specifications are subject to change without notice.



Printed July 2008
Printed in the USA