

Vertical Cutter Mixer



- All Stainless Steel Machine.
- Adjustable 3-blade knife assembly gives equal results for small or large batches.
- Bowl is easily removed for cleaning.
- Bowl tilts for easy removal of product.
- Polycarbonate lid designed to allow the addition of liquids or ingredients during processing.
- Digital timer for better preparation control.
- Stainless Steel Bowl and frame designed to be simple to use and to clean.
- Delivered with 63 Qt Stainless Steel Bowl and 3 Blade smooth knife assembly.
- 1 year parts and labor warranty.

63 Qt. Bowl Unit designed for vertical cutting and mixing: Mix, Chop, Puree, Blend, Mix and Knead Doughs.



Robot Coupe U.S.A., Inc.

P.O. Box 16625

Jackson, MS 39236-6625

1-800-824-1646 • (601) 898-8411

FAX: (601) 898-9134

www.robotcoupeusa.com • e-mail: info@robotcoupeusa.com

SPECIFICATIONS ON REVERSE SIDE

Specifications

STANDARD MODEL: includes motor base unit with 63 Quart Stainless Steel Bowl and smooth 3-blade assembly

ELECTRICAL REQUIREMENTS: 208-240V, 60 Hz, 60 Amp, three-phase. Contact your local electrician for local code requirements. NEMA 15-50P Plug.

SWITCHING: Control panel with push-type on / off buttons and 0-15 minute digital timer.

MOTOR: 16 HP, 1800/3600 RPM, three-phase

SAFETY: Magnetic safety and thermal protection, bowl detection device, lid detection device and locking lid detection devices

WEIGHT: 423 lbs. approximate shipping weight.

OPTIONAL EQUIPMENT: 3 blade course serrated knife assembly, 3 blade fine serrated knife assembly .

STANDARDS: ETL electrical & sanitation, cETL (Canada)

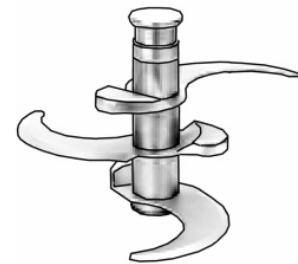
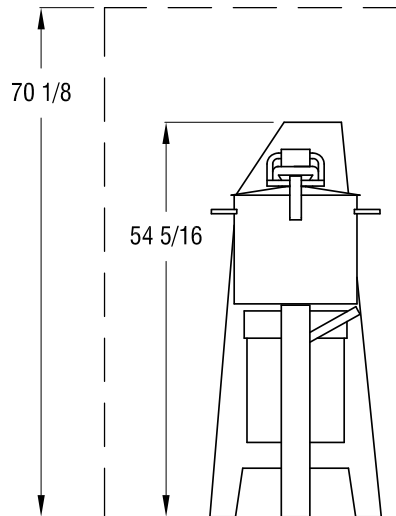
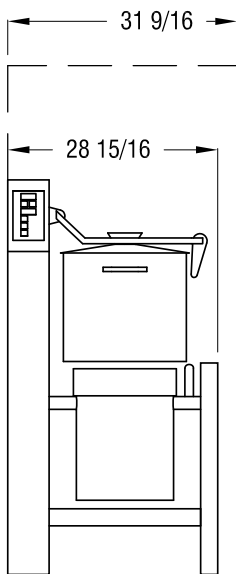
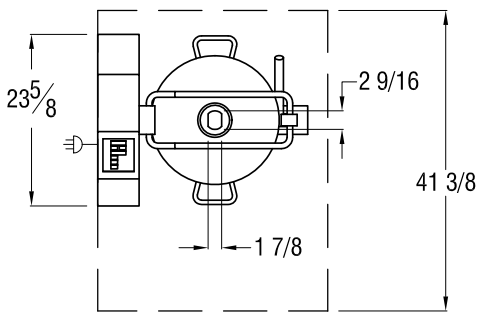

Three Blade Assembly

Robot Coupe U.S.A., Inc.
P.O. Box 16625
Jackson, MS 39236-6625
1-800-824-1646
(601) 898-8411
FAX: (601) 898-9134
www.robotcoupeusa.com
e-mail: info@robotcoupeusa.com

Distributed by: