

C3URLP 1 Shelf

**LOW PROFILE STRAIGHT FRONT
& SIDES DOUBLE GLASSES
REFRIGERATED PASTRY CASE**



C3URLP4

Standard Features

- Straight front and sides double glasses
- Internal cooling aggregate
- Dynamic cooling (ventilated) system
- External housing made of black/white coated steel
- Ecological polyurethane foam insulation
- Bottom shelf made of black/white melamine
- Back sliding doors with combined glass
- Front glass warm air blast
- Top and front frame include LED lighting
- Device leveling legs
- Automatic defrost system
- Automatic condenser vaporization system
- Electronic temperature controller with digital display
- Glass shelves with height and angle adjustment

LED lamps

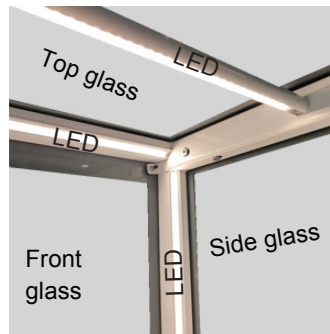

Options

- Multiple colours available

Metal element colours

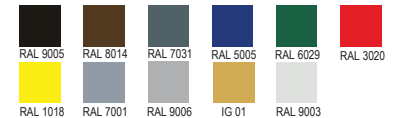

Technical Drawing

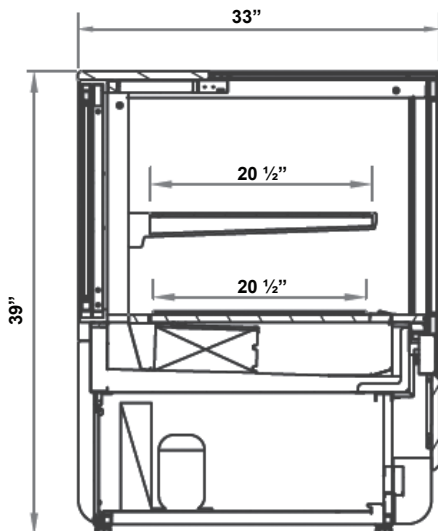

Dimensions

Model	Dimension W x D x H	Weight (lbs / kg)
C3URLP3	37" x 33" x 39"	441 - 200
C3URLP4	53" x 33" x 39"	-

Voltage

- C3URLP3 : 115V / 1ph / 60 Hz / 8A, max. fuse: 15A
- C3URLP4 : 115V / 1ph / 60 Hz / 12A, max. fuse: 15A

* Specifications are subject to change without notice.

**All measurements are approximates.

***All equipment are designed to operate in a controlled environment below 75°F (+24°C) temperature and HR 55% relative humidity.