

J2SCRP Straight glass

REFRIGERATED PASTRY CASE WITH SELF CLOSING SLIDING BACK DOORS



J2SCRP8

Standard Features

- Self Contained
- Static cooling
- Straight front glass
- Interior stainless steel finish
- Adjustable and removable wire shelves
- Each shelf includes LED lighting
- Stainless steel top counter
- Back self-closing doors on stainless steel rails
- Internal cooling aggregate
- 2 levels of white plastified reticulated shelves
- Leveling legs
- Automatic defrost system
- Automatic condenser vaporization system
- Electronic temperature controller with digital display

Options

- Multiple colours available
- Reticulated chromium coated shelf

Metal element colours



Plastic side colours

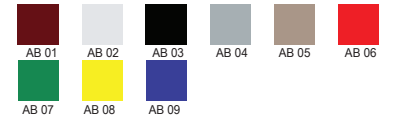

Aluminum profile colours



Technical Drawing

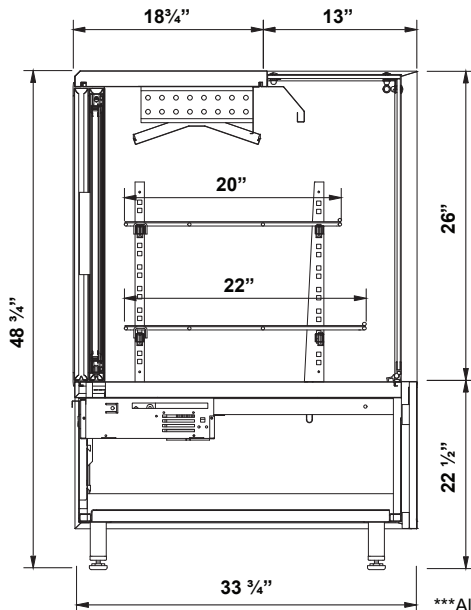

***All equipment are designed to operate in a controlled environment below 75°F (+24°C) temperature and HR 55% relative humidity.

Dimensions

Model	Dimension W x D x H	Weight (lbs / kg)
J2SCRP4	50 3/4" x 33 3/4" x 48 3/4"	337 / 153
J2SCRP6	75" x 33 3/4" x 48 3/4"	529 / 240
J2SCRP8	99 1/4" x 33 3/4" x 48 3/4"	661 / 300

Voltage

- J2SCRP4,6 : 115V / 1ph / 60 Hz / 8A, max. fuse: 15A
- J2SCRP8 : 115V / 1ph / 60 Hz / 16A, max. fuse: 20A

* Specifications are subject to change without notice.

**All measurements are approximates.