

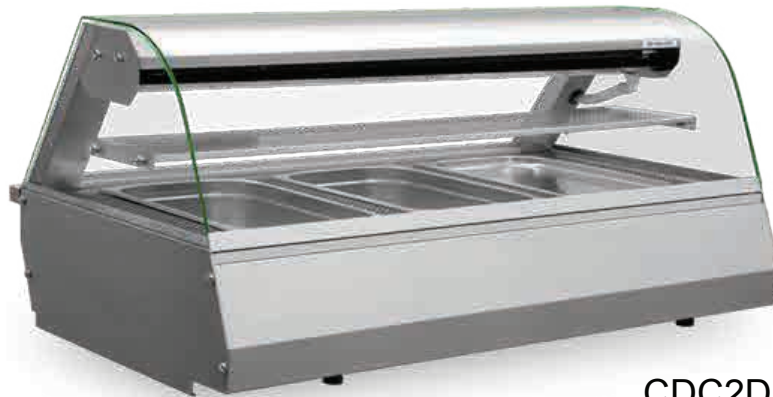

Instruction Manual

Countertop Refrigerated Display Cases

Models: CDCD
CDC2D



CDC2D



CDCD

124 Norfinch Dr. Toronto, ON. M3N 1X1
Tel : 416-663-3051 Fax : 416-663-5793
Toll Free : 1-888-408-8819

 **IGLOO**
REFRIGERATION LTD.

Contents

1 UNLOADING	3
2 PROPERTIES OF THE UNIT.....	3
2.1 Purpose	3
2.2 Description of the unit.....	3
2.3 Technical data.....	5
3. PREPARING THE DEVICE FOR START UP	5
3.1 Installation requirements	5
3.2 Unit Location	6
3.3 Connection and start-up.....	6
4. UNIT START UP	8
4.1 Temperature regulation	8
5. MAINTENANCE	10
5.1 Cleaning and maintenance	12
6. SERVICE.....	14
6.1 Faults identification and repair	14
6.2 Service.....	15

List of Figures

Figure 1 “CDCD” overview	4
Figure 2 “CDC2D” overview.....	4
Figure 3 CDCD container layouts	4
Figure 4 CDC2D container layouts	5
Figure 5 Assembly/ disassembly of elements in “CDCD” unit	7
Figure 6 Assembly/ disassembly of elements in “C2DCD” unit.....	7
Figure 7 Control panel	8
Figure 8 Ventilation holes of the unit	8
Figure 9 “Carel” thermostat control panel	9
Figure 10 Disassembly of the front glass.....	13
Figure 12 Cleaning the condenser in “CDC2D” unit	13

List of Tables

Table 1 Cross-bars under containers.....	5
Table 2 Technical data	5
Table 3 Table of alarms and signals	10
Table 4 Table of easy compact parameters for model CDCD and CDC2D.....	11

1 UNLOADING

The unit should be transported in the vertical position and properly secured and packed.

2 PROPERTIES OF THE UNIT

2.1. Purpose

“CDC” is a universal cooling device used to store and display a wide assortment of grocery products previously cooled to storage temperature. “CDC” is adjusted to display products in gastronomic containers. Our display cabinets ensure universal and efficient display area for all types of commercial and gastronomic units, such as restaurants, pizza houses, bars, fast food bars, pubs, etc.

2.2. Description of the unit

“CDC” is equipped with static cooling and is manufactured with self-contained compressor.

The display case is equipped with electronic thermostat, automatic defrosting and automatic condensate evaporation.

“CDC” is a display cabinet made of stainless steel, used for gastronomic containers.

Optional version may be equipped with perforated stainless steel shelf. Front glass of the device is cured and lifted.

The temperature inside the display cabinet equals +1°C/+4°C with ambient temperature of +15°C/+25°C and relative air humidity of up to 55%.

Our equipment is manufactured in accordance of modern technologies and has all certificates required by law.

The description in this box signifies important information for user security and for proper operation of the device.

Figure 1 “CDCD” overview

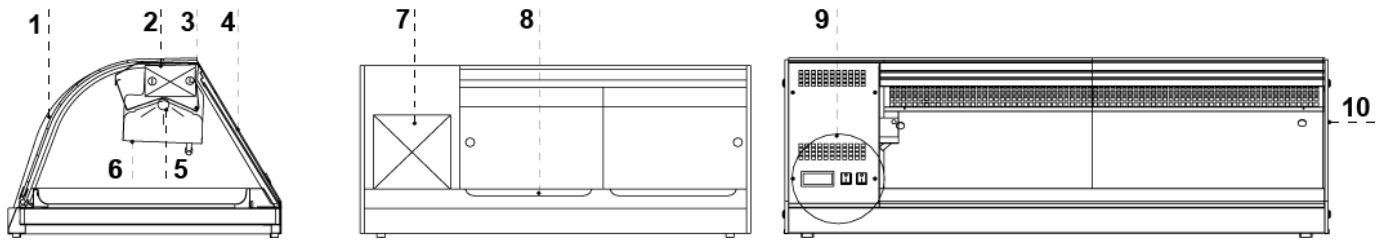

- 1 – Curved front glass, lifted (when removed – access to condensate lamellas)
- 2 – Evaporator
- 3 – Evaporator screen
- 4 – Night screen
- 5 – LED lamp
- 6 – Rail (condensate outflow for evaporator defrosting)
- 7 – **Cooling aggregate**
- 8 – Containers
- 9 – Control panel
- 10 – Glass sides

Figure 2 “CDC2D” overview

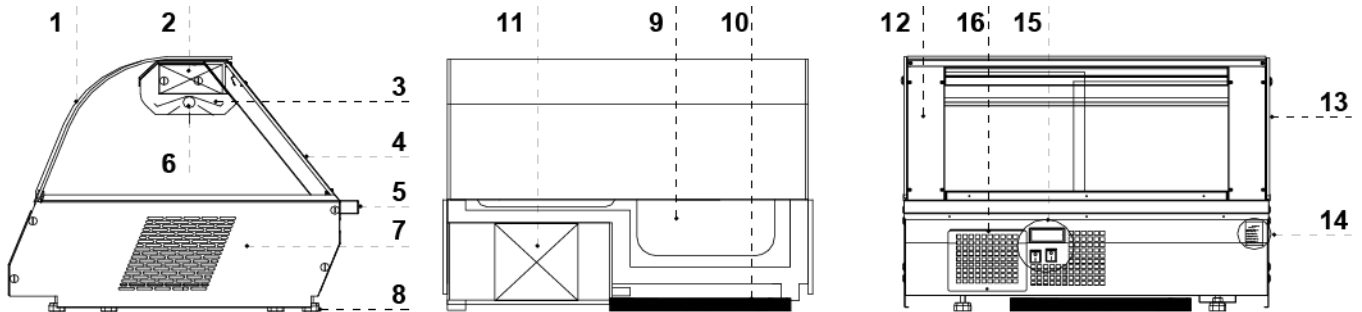

- 1 – Curved front glass, lifted
- 2 – Evaporator
- 3 – Rail (condensate outflow for evaporator defrosting)
- 4 – Night screen
- 5 – Top
- 6 – LED lamp
- 7 – Side metal plate (when removed – access to aggregate)
- 8 – Leveling legs
- 9 – Containers
- 10 – Condensate tray
- 11 – **Cooling aggregate**
- 12 – **Horn hole plug (when removed – access to tubing of the cooling part and electrical conduits)**
- 13 – Glass sides
- 14 – Serial plate
- 15 – Control panel
- 16 – Condenser cover (when removed – access to condenser lamellas) (Do not block the air louver)

Figure 3 CDCD container layouts

CDCD2

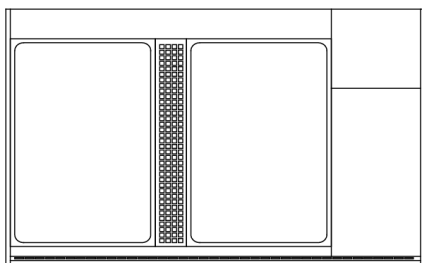

CDCD3

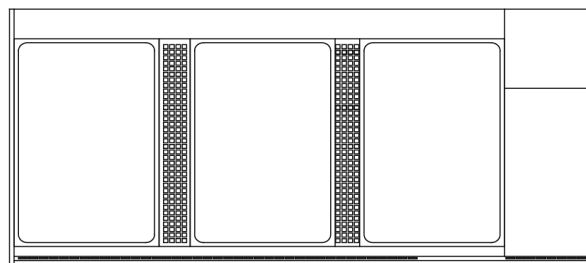

Figure 4 CDC2D container layouts

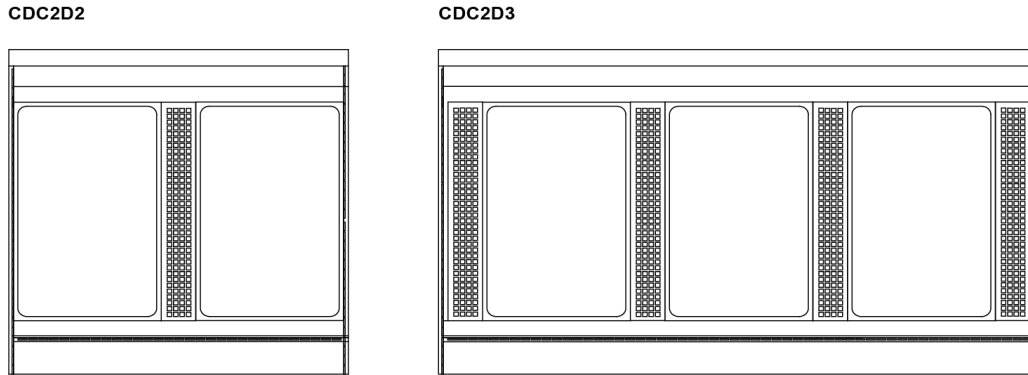

Table 1 Cross-bars under containers

Model	CDCD2	CDCD3	CDC2D	CDC2D3
Number of cross-bars	2	3	2	3

2.3. Technical data

Table 2 Technical data

Model	Voltage [V/HZ/PH]	Rated Current [A]	Weight [lbs/kg]
CDCD2	115/60/1	4 (max.fuse:15)	121/55
CDCD3	115/60/1	4 (max.fuse:15)	165/75
CDC2D2	115/60/1	4 (max.fuse:15)	132/60
CDC2D3	115/60/1	4 (max.fuse:15)	190/86

3. PREPARING THE DEVICE FOR START UP

The unit must be properly installed and located in accordance with the installation instructions before it is used.

3.1. Installation requirements

- Always use a dedicated circuit with the amperage stated on the unit.
- Plug into an outlet designed for the plug.
- Do not overload the circuit.
- Do not use extension cords.
- Never use adapters.
- Never plug in more than one unit per electric circuit.
- If in doubt, call an electrician.

IGLOO will not warranty any equipment that is connected to an extension cord or an adapter plug.

The equipment may be turned on after confirmation of the fire protection efficiency with results of measures performed according to binding regulations!

■ NEMA Plugs

IGLOO refrigeration uses this type of plug. If you do not have the right outlet have a certified electrician install the correct power source.

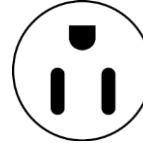

115/60/1
NEMA-5-15R

3.2. Unit Location

- Install the unit on a strong and leveled surface.
- To ensure proper operation the unit must be leveled from front to back and left to right.
- Unit may malfunction if improperly leveled.
- Ensure sufficient ventilation around the entire unit.
- Select a location away from heat and moisture generating equipment.
- Avoid installation in a high ambient or humid location.
- High ambient temperatures will cause the compressor to overwork.
- Humidity may cause rust, condensation around glass or stainless steel and decrease the efficiency of the unit.

3.3. Connection and start-up

- Unpack the unit.
- To securely transport the equipment, the unit may be shipped partially disassembled. If the user received the unit partially disassembled, perform the following operations:
 1. Place cross-bars under containers
 2. Place containers
 3. Place containers
 4. (This concerns only “CDC2D”) Place condensate tray under the water outflow funnel (overflow) located under the display case. Push the tray from the front of the unit.
- The equipment should be cleaned right after unpacking and before turning it on. The unit should be cleaned with warm water not exceeding 40°C with a neutral detergent. For washing and cleaning the equipment, it is prohibited to use products containing chlorine and sodium varieties, which destroy the protective layer and components of the equipment! Any residue of adhesives or silicone on metal elements should be removed only with extraction naphtha (not applicable to items made of plastic). Do not use other organic solvents.

When cleaning the unit, do not use water jet. The unit should be cleaned with a moist cloth.

After installation of the equipment at the destination location it should be left to rest for at least 2 hours before turning it on (for devices with built-in compressor) to set the level of refrigerant in order to prevent problems with the start up.
WARNING: Keep the cooling circuit away from damage!

- Turn on the main switch. (Figure. 7/1)
- The temperature on the thermostat control panel is PRE SET. (Figure 7/3)
- Turn on the light switch. (Figure. 7/2)

Figure 5 Assembly/ disassembly of elements in “CDDC” unit

- 1 – Upper aluminum profile of the glass (lifted guide)
- 2 – Lower aluminum profile of the glass (catch)
- 3 – Cured front glass, lifted
- 4 – Glass side
- 5 – Container
- 6 – Container separator
- 7 – Night screen

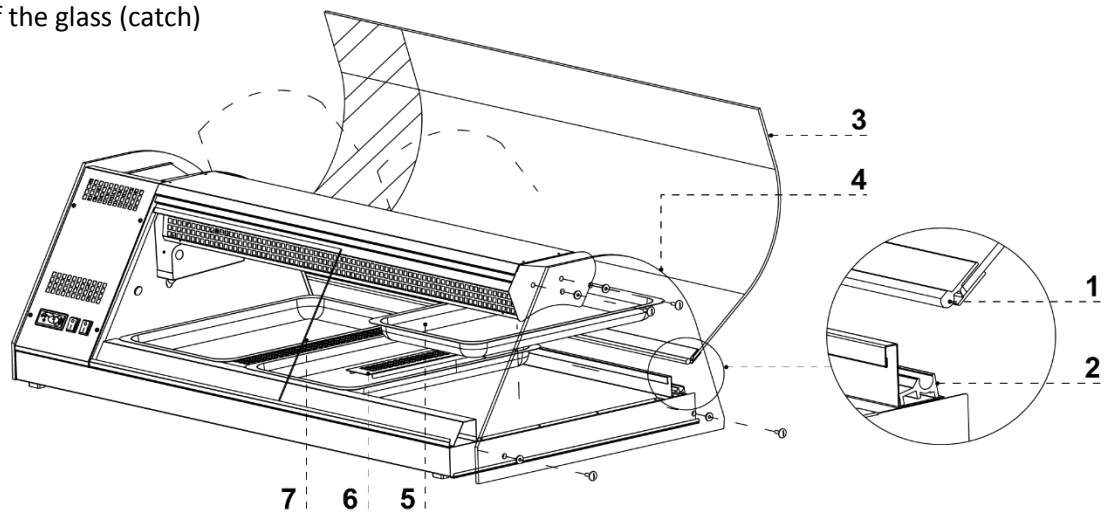

Figure 6 Assembly/ disassembly of elements in “C2DDC” unit

- 1 – Upper aluminum profile of the glass (lifted guide)
- 2 – Lower aluminum profile of the glass (catch)
- 3 – Cured front glass, lifted
- 4 – Glass side
- 5 – Container
- 6 – Night screen
- 7 – Container separator
- 8 – Leveling feet

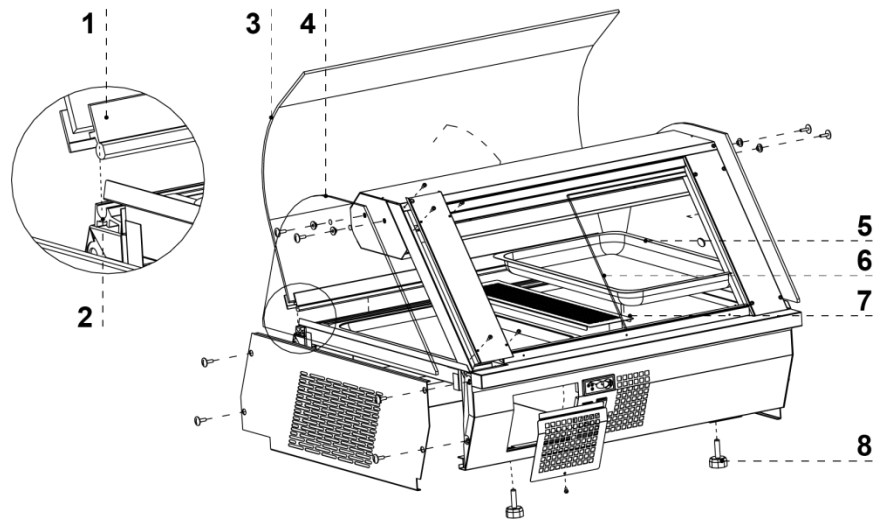
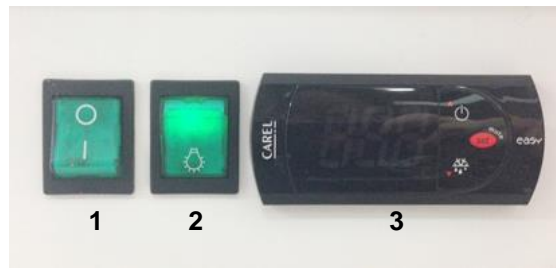

Figure 7 Control panel

- 1 - Main switch (turns on/off the unit)
- 2 - Light switch
- 3 - Thermostat (temperature regulator) panel
(Service details in Chapter 4)



4. UNIT START UP

The temperature of the cooled space and aggregate operating cycle may fluctuate. This depends on numerous factors, such as the amount and temperature of products placed in the device and temperature of the surroundings. The equipment should be placed in a dry and well-ventilated area, ensuring proper air exchange (distance between the wall and the equipment– min. 10cm), out of sunlight, kept far from heat sources and devices enforcing air flow (ceiling and portable ventilators, blow-in heaters). The equipment functions properly in a room, where temperature falls within appropriate climatic class. The operation of the equipment may worsen when operates outside the stated temperature range.

Remarks and indications

- ***After transporting the equipment, wait about 2 hours before the start up the unit.***
- ***The first filling of shelves should be performed after the unit reached desired cooling temperature. This principle should also be observed after long pause in the operation.***
- ***Do not block any ventilation holes, which would hamper the circulation of the cooled air. It is also necessary to ensure proper airflow around the equipment.***
- ***Keep the condenser clean. Impurities may lead to overheating of the compressor and may result in damage, which is not covered by the warranty.***
- ***Do not use electric devices inside the product storing chamber.***

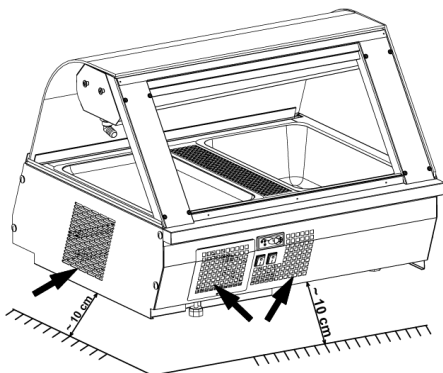

Figure 8 Ventilation holes of the unit

DO NOT BLOCK VENTILATION HOLES!!! Minimal distance between ventilation holes of the device and other elements of the equipment (furniture) or walls should equal at least about 10 cm.

4.1. Temperature regulation

The thermostat is to obtain the set temperature within the equipment and maintain it within the determined temperature ranges. The manufacturer enters all settings of temperature regulators required for normal functioning of the equipment. Before primary actuation the user should control and possibly set the required temperature inside the equipment on the control panel.

Digital display – displays the current temperature inside the equipment.

It is forbidden to interfere with systemic parameters of the thermostat, as this can lead to serious consequences, including the damage of the cooling unit!

Figure 9 “Carel” thermostat control panel

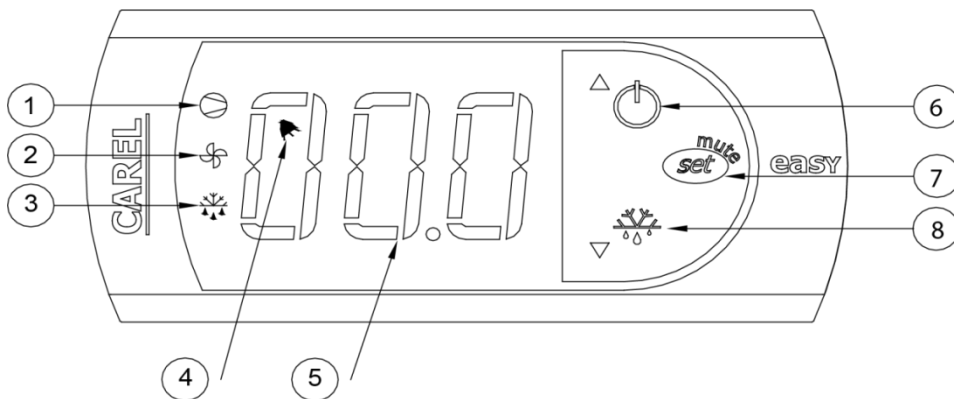

WHAT DO DIODES ON CONTROL PANEL SIGNIFY

Diode 1 - Compressor: This symbol is visible when the compressor is working. It is blinking when compressor actuation is delayed by security procedure. It blinks in the following cycle: two blinks – pause, when the constant working mode is activated.

Diode 2 - Ventilator: This symbol is visible when evaporator ventilators are turned on. It blinks when the actuation of the ventilators is delayed by external disengagement or when another procedure is in progress.

Diode 3 - Defrosting: This symbol is visible when the defrosting function is activated. It blinks when the actuation is delayed by external disengagement or when another procedure is in progress.

Diode 4 - Alarm: This symbol is visible when the alarm is activated.







Diode 5 - Current temperature inside the equipment is displayed (decimal places displayed after the comma).

Diode 6 – On/Off Switch: Pressing this button alone: for more than 3 sec. switch On/Off, **Pressing with other buttons:** pressed together with 8 activities/deactivates the continuous cycle.

Diode 7 – Set/ Mute: Pressing this button alone: 1 sec. displays /sets the set point, more than 3 sec. accesses the parameter setting menu (enter password 22), mutes the audible alarm (buzzer), **Start Up:** hold the set/mute button for 1 sec. RESET current EY set / Pressed together (7 and 8) activate parameter reset procedure.

Diode 8 – Defrost: Pressing this button alone: more than 3 sec. activates/deactivates the defrost. **Pressing with other buttons:** pressed together with 6 activates/deactivates the continuous cycle, **Start Up:** hold for 1 sec. displays firmware version.

SETTING THE DESIRED TEMPERATURE

- Press the set button  for 1 second leading value shall be displayed on the screen
- Increase or decrease the leading value by means of   and  and , until the desired value shall be obtained;
- Press the set button  once again in order to confirm the new value of the setting point.

MANUAL INPUT OF THE DEFROSTING CYCLE

Defrosting shall be released in an automatic mode. It is possible to force defrosting at any moment by pressing and holding the  defrost switch for minimum 5 seconds.

Table 3 Table of alarms and signals

alarm code	buzzer and alarm relay	LED	alarm description	reset
E0	active	ON	probe 1 error= control	automatic
E1	active	ON	probe 2 error= defrost	automatic
E2	active	ON	probe 3 error= condenser/product	automatic
EE	active	ON	unit parameter error	not possible
EF	active	ON	operating parameter error	manual
Ed	not active	ON	defrost ended by timeout	On first defrost ended correctly
CHt	active	ON	dirty condenser alarm	manual

MODIFYING THE PARAMETERS

Parameter navigation

The operating parameters, modifiable using the keypad, are divided into two types: frequent (type F) and configuration (type C). Access to the latter is protected by password (default= 22) to prevent accidental or unauthorized modifications.

Accessing the type F parameters:

- Press the SET button for more than 3 s (if there are active alarms, mute the buzzers). The display shows the parameter code 'PS' (password);
- Use the UP and DOWN buttons to scroll the parameters. The LED corresponding to the category of parameters will be on;
- Press SET to display the value associated with the parameter
- Increase or decrease the value using the UP or DOWN button respectively;
- Press SET to temporarily save the new value and display the parameter again;
- Repeat the procedure for any other parameters that need to be modified;
- Press the SET button for more than 3 s to permanently save the parameters and exit the parameter setting procedure.

Table 4 Table of easy compact parameters for model CDCD and CDC2D

Par.	Description	Def.	UOM.	Min	Max
St	set point	1	°C	r1	r2
PS	password	22	-	0	99
/2	probe measurement stability	4	-	1	15
/4	select probe displayed	1	-	1	3
/5	select °C/°F	0	-	0(°C)	1(°F)
/6	disable decimal point	0	-	0	1
/C1	probe 1 offset	0.0	°C	-50.0	50.0
/C2	probe 2 offset	0.0	°C	-50.0	50.0
/C3	probe 3 offset	0.0	°C	-50.0	50.0
rd	control differential	3.0	°C	0	19.0
r1	minimum set point value	0.0	°C	-50.0	r2
r2	maximum set point value	15.0	°C	r1	99
r3	select direct/reverse operation	0	-	0	2
r4	night-time set point delta	3.0	°C	-50	50
c0	compressor and fan start delay on power-up	1	min	0	100
c1	minimum time between consecutive compressor starts	1	min	0	100
c2	minimum compressor off time	1	min	0	100
c3	minimum compressor on time	0	min	0	100

c4	compressor on time with duty setting	50	min	0	100
cc	continuous cycle duration	2	2	0	15
c6	temperature alarm bypass after continuous cycle	2	h	0	15
d0	type of defrost	0	-	0	4
d1	interval between defrosts	8	h	0	199
dt	end defrost temperature set point	12.0	°C	-50	130
dP	maximum defrost duration	60	min	1	199
d4	defrost when switching the instrument on	0	-	0	1
d5	defrost delay on power-up or when enabled by digital input	0	min	0	199
d6	freeze control temperature display during defrost	1	-	0	1
dd	dripping time	2	min	0	15
d8	alarm bypass time after defrost	1	h	0	15
d9	defrost priority over compressor protectors	0	-	0	1
d/	defrost probe reading (2)	-	°C	-	-
dC	time base	0	-	0	1
A0	alarm and fan temperature differential	2.0	°C	-20	+20
AL	absolute/relative temperature for low temperature alarm	0.0	°C	-50	+99
AH	absolute/relative temperature for high temperature alarm	0.0	°C	-50	+99
Ad	temperature alarm delay	0	min	0	199
A4	3rd input configuration	0	-	0	11
A7	digital input alarm delay	0	min	0	199
A8	enable alarm "Ed" (end defrost by timeout)	0	-	0	1
Ac	set point dirty condenser alarm	60	°C	-50	250
AE	dirty condenser alarm differential temperature	3.0	°C	0.1	20
Accd	dirty condenser alarm delay	0	min	0	250
H0	serial address	1	-	0	207
H1	AUX output configuration	0	-	0	2
H2	enable keypad	1	-	0	2
H4	disable buzzer	0		0	1
H5	ID code (read-only)	-1	-	1	+199
EZY	restore the Default settings	2	0	0	1

5. MAINTENANCE

- Do not use steel wool, abrasive cleaners, bleach or cleaners containing chlorine or sodium to clean the unit.
- Do not use pressure washer or water-jet to clean the unit.
- The unit should be cleaned right after unpacking and before turning it on.
- The unit should be cleaned with warm water and mild soap.
- Make sure to cover the fan motor to prevent moisture damage.
- Door gaskets, shelves and supports should be cleaned on a regular basis.
- Fan blades and guards should be cleaned with a soft cloth.

5.1 Cleaning and maintenance

• ***All maintenance service needs to be performed after disconnecting the unit from the power supply!***

- **Protect electrical components against any damages or water spillage.**
- **Do not use water stream to clean the equipment, only a moist cloth.**
- **Do not use any sharp objects to remove dirt!**
- **When cleaning inside of the device do not leave the front glass panel lifted in the aluminum profile, this may cause damage to the glass and is not covered by warranty. Please remove the glass with profile during the cleaning process. (Figure 11)**

Figure 10 Disassembly of the front glass

- 1 – Front glass
- 2 – Upper aluminum profile (lifted guide) of the glass
- 3 – Lower aluminum profile (hinge) of the glass

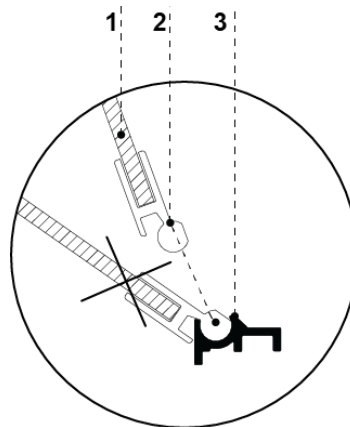

When using the display case, as well as during maintenance works, pay attention not to damage the temperature sensor in the evaporator screen!

Do not use mechanical agents to quicken the defrosting process!

It is recommended to make a break in the operation **once a month** in order to clean the interior, naturally defrost the evaporator and clean the condenser.

Figure 11 Cleaning the condenser in “CDC2D” unit

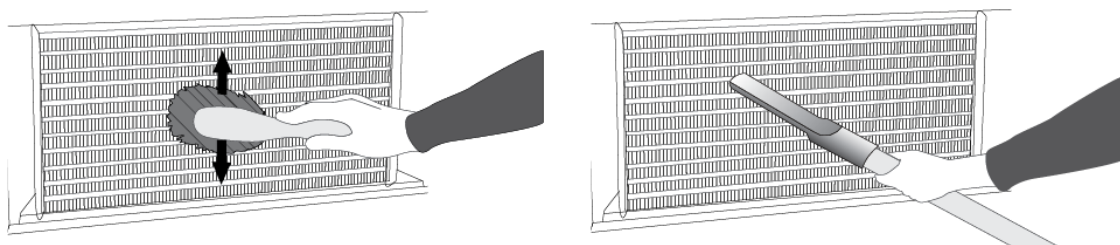

(This concerns the “CDCD” unit) In order to clean the condenser it is essential to remove the front glass of the unit.
 (This concerns the “CDC2D” unit) In order to clean the condenser it is necessary to unscrew the sheet metal screw and remove the air louver.

It is essential to keep the condenser of the device clean. Dirt may hinder the heat exchange, causing increase in electricity consumption and may cause damage to the compressor. In order to clean the condenser it is necessary to unscrew the sheet metal screws and pull the wind brace out of catch by lifting it up. Clean condenser lamellas with help of soft brush or paint brush. If the condenser is extremely dirty (blocking of lamellas), use vacuum cleaner or compressed nitrogen to remove dirt from between lamellas.

The seller shall not be held responsible for any condenser damages in the case of non-observance of condenser cleaning instructions.

Elements of equipment can corrode as result of improper use and maintenance.

To prevent damage:

Do not allow contact of the with substances containing chlorine and/ or baking soda in different varieties, which destroy the protective layer and components of the equipment (also includes various stainless steel)

6. SERVICE

6.1. Faults identification and repair

In case of any difficulties during actuation of the equipment or during its operation, please return to the chapters in this manual, which explain the performed operation. This aims to ensure the equipment is properly operated. If you still experience difficulties, the following might help you solve the problems.

The equipment is not working... – Make sure that:

- The equipment is connected to the power supply.
- Voltage and frequency in the network are compliant with those recommended by the manufacturer, 115V/60Hz.
- The main switch is turned on.
- Thermostat is turned on.

The equipment is operating, but the light is off... – Make sure that:

- Light switch is turned on.
- Lamp or starting switch of the equipment is not burnt.

Water leakage from under the device

- Check whether the equipment is properly levelled.
- Empty the condensate container.

The equipment does not reach the proper temperature, the light is on... – Make sure that:

- The main switch is on.
- Temperature setting on the thermostat is properly set.

- Thermostat works properly.
- The condenser is clean, if necessary – clean the condenser.
- Ambient temperature does not exceed 25°C.
- Enough time has passed for products to be cooled.
- Ventilation holes are not blocked.

The equipment is working too loud... – Make sure that:

- The equipment is standing stably and properly levelled.
- Furniture adjoining the equipment does not vibrate when self-contained compressor is working.

Noises made by the operating device is normal. The units are equipped with ventilators, engines and compressors, which turn on and off automatically. Each compressor makes certain noises when operating. These sounds are made by the aggregate engine and by cooling agent flowing through the circuit. This phenomenon constitutes a technical feature of cooling devices and does not signify equipment failure.

Steam precipitation on the glass is a normal phenomenon in the event of high relative air humidity exceeding 60% and does not require calling for service.

6.2 Service

IGLOO Refrigeration service

Telephone number: 416-663-3051 or (toll free) 1-888-408-8819

E-mail: service@igloo400.com

If after checking points described in chapter 6.1 “Faults identification and repair” the equipment still does not work properly, Please contact Technical Service @ IGLOO Refrigeration.