



# Instruction Manual

---

## Pastry Display Cases

Models: JOR series



JORPP



JORTP



JORWP

124 Norfinch Dr. Toronto, ON. M3N 1X1  
Tel : 416-663-3051 Fax : 416-663-5793  
Toll Free : 1-888-408-8819

 **IGLOO**  
REFRIGERATION LTD.

## Contents

1 UNLOADING .....	3
2 PROPERTIES OF THE UNIT.....	3
2.1. Purpose .....	3
2.2. Description of the unit.....	3
2.3. Technical data .....	4
3. PREPARING THE DEVICE FOR START UP .....	5
3.1. Installation requirements .....	5
3.2. Unit Location .....	5
3.3. Connection and start-up .....	6
4. UNIT START UP .....	9
4.1. Temperature regulation .....	9
5. MAINTENANCE .....	10
5.1 Cleaning and maintenance .....	10
6. SERVICE .....	15
6.1. Faults identification and repair .....	15
6.2 Service .....	16

## List of Figures

Figure 1 "JOR" series overview .....	4
Figure 2 Caster wheels .....	5
Figure 3 Mounting glass shelves .....	7
Figure 4 Install the door handle .....	7
Figure 5 Control panel .....	7
Figure 6 Ventilation holes of the device.....	8
Figure 7 "Carel" thermostat control panel .....	10
Figure 8 Cleaning the condenser .....	14

## List of Tables

Table 1 Technical data .....	4
Table 2 Table of alarms and signals .....	11
Table 3 Table of easy compact parameters .....	12

## 1 UNLOADING

The unit should be transported in vertical position and properly secured and packed.

## 2 PROPERTIES OF THE UNIT

### 2.1. Purpose

“JOR” series display cases are universal cooling devices aimed to display and short-term storage for confectionery goods (such as cakes, cookies, desserts... etc.) in temperatures between +4°C and +8°C with ambient temperature between +15°C and +25°C and relative air humidity not exceeding 60%, depending on the environment and the location of the unit.

### 2.2. Description of the unit

“JOR” series display cases are equipped with internal aggregate and forced air circulation. This display case is equipped with automatic defrosting and automatic condensate evaporation. Glass shelves, rotating or fixed, with height regulation, constitute the display part of the case. “JOR” series are available in stationary or mobile version. Our equipment is manufactured according to modern technologies and all have certificates required by law.

***This symbol signifies important information for user security and for proper operation of the device.***

Figure 1 "JOR" series overview

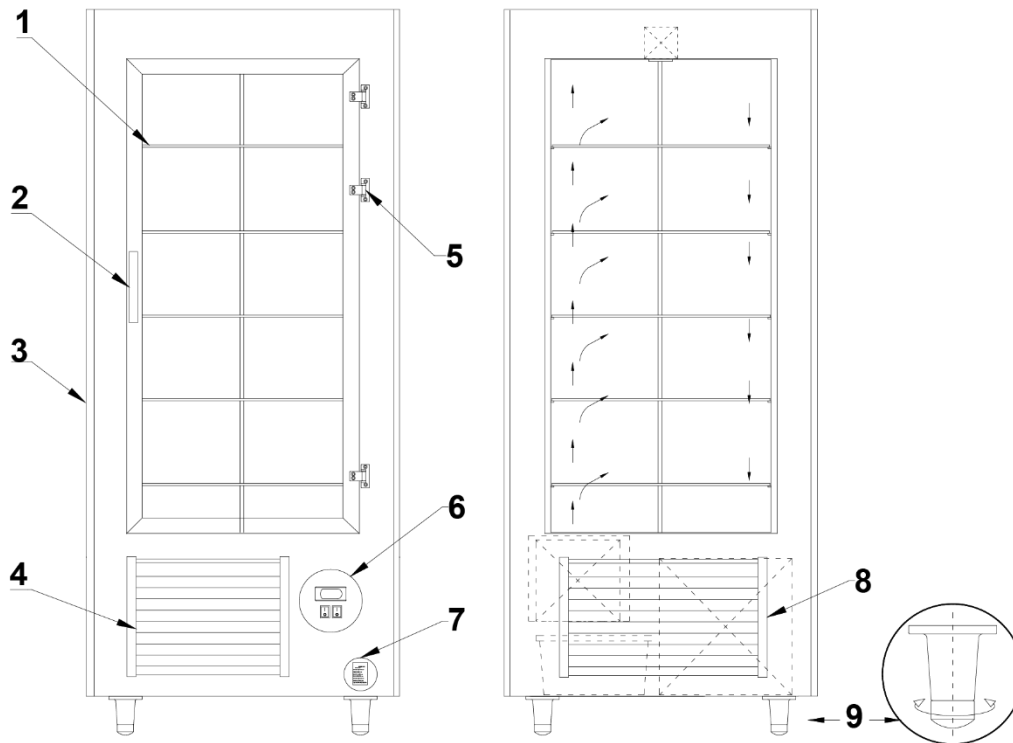

- 1 - Glass shelves (rotating or fixed)
- 2 - Door handle
- 3 - Casing (metal/wooden/trand)
- 4 - Front air louver (DO NOT BLOCK ventilation holes)

- 5 - Door hinge
- 6 - Control panel
- 7 - Serial plate
- 8 - Side, left air louver (access to condenser)
- 9 - Leveling feet

## 2.3. Technical data

Table 1 Technical data

Model	Voltage [V/Hz/Ph]	Rated Current [A]	Max shelf load [lbs/kg]	Weight [lbs/kg]
JORPP (Painted metal)	115/60/1	8 (max.fuse:15)	33/15	341/155
JORWP (Wood finish)	115/60/1	8 (max.fuse:15)	33/15	407/185
JORTP (Enamel finish)	115/60/1	8 (max.fuse:15)	33/15	407/185
JORPP w/rotating shelves	115/60/1	8 (max.fuse:15)	22/10	352/160
JORWP w/rotating shelves	115/60/1	8 (max.fuse:15)	22/10	419/190
JORTP w/rotating shelves	115/60/1	8 (max.fuse:15)	22/10	419/190

### 3. PREPARING THE DEVICE FOR START UP

***The unit must be properly installed and located in accordance with the installation instructions before it is used.***

#### 3.1. Installation requirements

- Always use a dedicated circuit with the amperage stated on the unit.
- Plug into an outlet designed for the plug.
- Do not overload the circuit.
- Do not use extension cords.
- Never use adapters.
- Never plug in more than one unit per electric circuit.
- If in doubt, call an electrician.

***IGLOO will not warranty any equipment that is connected to an extension cord or adapter plug.***

***The equipment may be turned on after confirmation of the fire protection efficiency with results of measures performed according to binding regulations!***

■ NEMA Plugs  
IGLOO refrigeration uses this type of plugs. If you do not have the right outlet have a certified electrician install the correct power source



115/60/1  
NEMA-5-15R

#### 3.2. Unit Location

- Remove cardboard angles and protective foil.
- Install the unit on a strong and leveled surface.
- For mobile units, use wheel lock to immobilize the unit before use. (Figure 2)

**Figure 2 Caster wheels**

A - Moving position

B - Brake

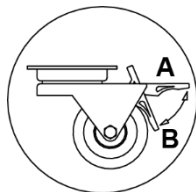

- To ensure proper operation the unit must be leveled from front to back and left to right.
- Unit may malfunction if improperly leveled.
- Ensure sufficient ventilation around the entire unit.
- Select a location away from heat and moisture generating equipment.
- Avoid installation in a high ambient or humid location.

- High ambient temperatures will cause the compressor to overwork.
- Humidity may cause rust, condensation around glass or stainless steel and decrease the efficiency of the unit.

### 3.3. Connection and start-up

- To securely transport the equipment, the unit may be shipped partially disassembled. If the user received the unit partially disassembled, perform the following operations:
  1. Screw the door handle. (Figure 3)
  2. Install shelf grips in perforated frame strips. (Figure 4/2) The frame may be a rotating frame or fixed frame depending on the version of the unit.
  3. Stick silicon glass protective pads on shelf grips. (Figure 4/4)
  4. Place glass shelves on fixed grips. (Figure 4/1)

“JOR” series display cases are equipped with 5 regulated round or rectangular glass shelves (depending on the option). The case with rotating frame is equipped with four upper glass shelves and a bottom mirror.

- The equipment should be cleaned right after unpacking and before turning it on. The unit should be cleaned with warm water not exceeding 40°C with a neutral detergent. For washing and cleaning the equipment, it is prohibited to use products containing chlorine and sodium varieties, which destroy the protective layer and components of the equipment! Any residue of adhesives or silicone on metal elements should be removed only with extraction naphtha (not applicable to items made of plastic). Do not use other organic solvents.

***When cleaning the unit, do not use water jet. The unit should be cleaned with a moist cloth.***

***After the installation of the equipment at the destination location it should be left to rest for at least 2 hours before turning it on (for devices with built in compressor) to set the level of refrigerant in order to prevent problems with the start up.***  
***WARNING: Keep out the cooling circuit from damage!***

- Turn on the main switch. (Figure 5/1)
- The temperature on thermostat control panel is PRE SET. (Figure 5/3)
- Turn on the light switch. (Figure 5/2)
- Turn on the frame rotating switch. (optional)

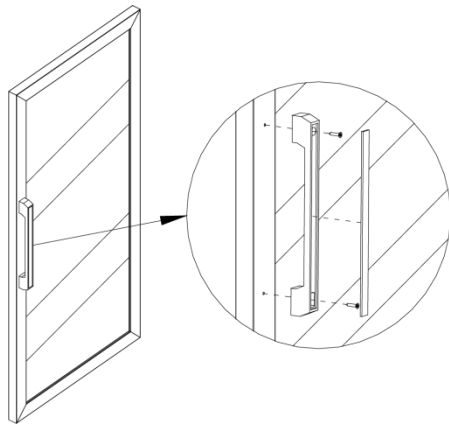

**Figure 4 Install the door handle**

**Figure 3 Mounting glass shelves**

- 1 – Glass shelf
- 2 – Shelf fixing grip
- 3 – Perforated frame strip
- 4 – Silicon glass protective pads (glue to the shelf grip to prevent movement)

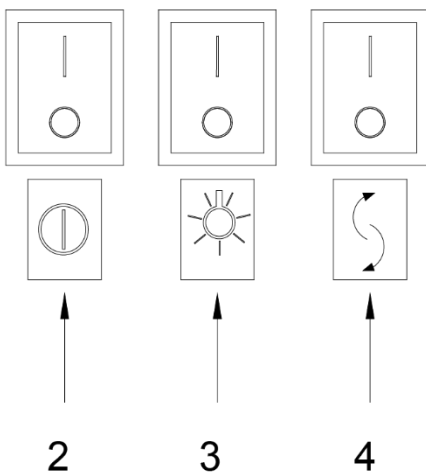
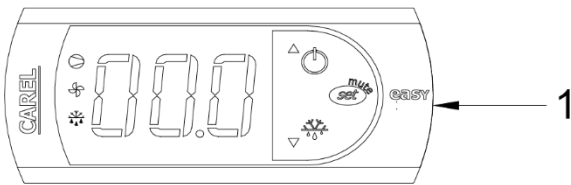
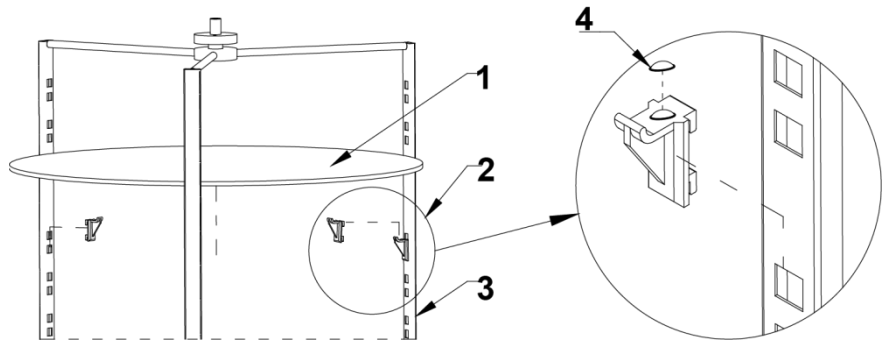

**Figure 5 Control panel**

- 1 – Thermostat panel (temperature regulator)  
(Service details in Chapter 4)
- 2 – Main switch (turns on/off the unit)
- 2 – Light switch
- 3 – Rotation switch

***For the rotating frame model, the frame rotation stops when the door is opened for safety measures. Closing the door will reactivate the rotation movement.***

## 4. UNIT START UP

The temperature of the cooled space and aggregate operating cycle may fluctuate. This depends on numerous factors, such as the amount and temperature of products placed in the device and temperature of the surroundings. The equipment should be placed in a dry and well-ventilated place, ensuring proper air exchange (distance between the wall and the equipment– min. 10cm), out of sunlight, kept far from heat sources and devices enforcing air flow (ceiling and portable ventilators, blow-in heaters). The equipment functions properly in a room, where temperature falls within appropriate climatic class. The operation of the equipment may worsen when operates outside the stated temperature range.

**\*\*\*\* Place products evenly in the center of the rotating shelf, to keep the balance even \*\*\*\***

***DO NOT BLOCK VENTILATION HOLES!!! Minimal distance between ventilation holes of the device and other elements of the equipment (furniture) or walls should equal at least about 10 cm.***

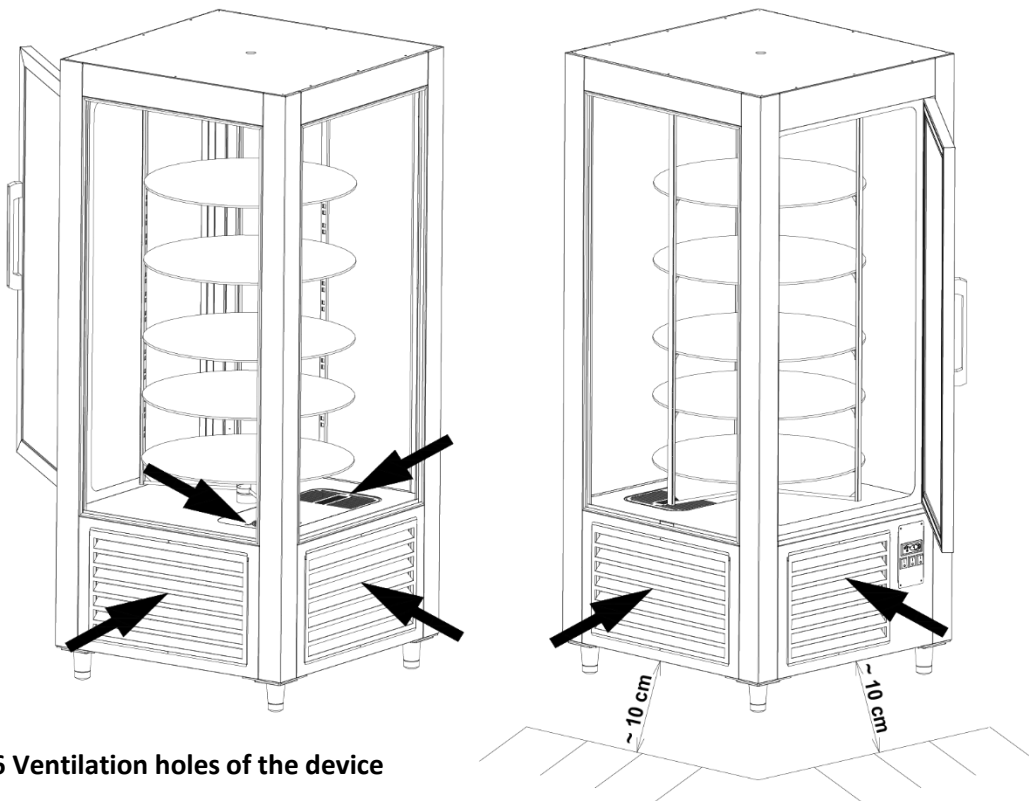

**Figure 6 Ventilation holes of the device**



## Remarks and indications

- *After transporting the equipment, wait about 2 hours before the start up.*
- *To ensure proper conditions for the stored products, do not load the shelves completely. Ensure even load of shelves and not to exceed the maximum load.*
- *The first filling of shelves should be performed after the unit reached desired cooling temperature. This principle should also be observed after long pause in operation.*
- *Do not place hot products in the cooling unit.*
- *Do not block any ventilation holes, which would hamper circulation of the cooled air. Also ensure proper airflow around the equipment.*
- *Keep the condenser clean. Impurities may lead to overheating of the compressor and may result in damage, which is not covered by warranty.*
- *Do not use electric devices inside the product storing chamber.*
- *After the door is closed, negative pressure inside the unit will make the door harder to open. Do not reopen the door with force. The pressure inside will balance within 1-2 minutes, which allows the door to be opened with ease.*
- *Avoid unnecessary opening of the doors and leaving them open for a longer period of time.*

### 4.1. Temperature regulation

The thermostat is to obtain the set temperature within the equipment and maintain it within the determined temperature ranges. The manufacturer enters all settings of temperature regulators required for normal functioning of the equipment. Before primary actuation the user should control and possibly set the required temperature inside the equipment on the control panel.

Digital display – displays the current temperature inside the equipment

***Do not interfere with systemic parameters of the thermostat, as this can lead to serious consequences, including damages to the cooling unit!***

**Figure 7 “Carel” thermostat control panel**

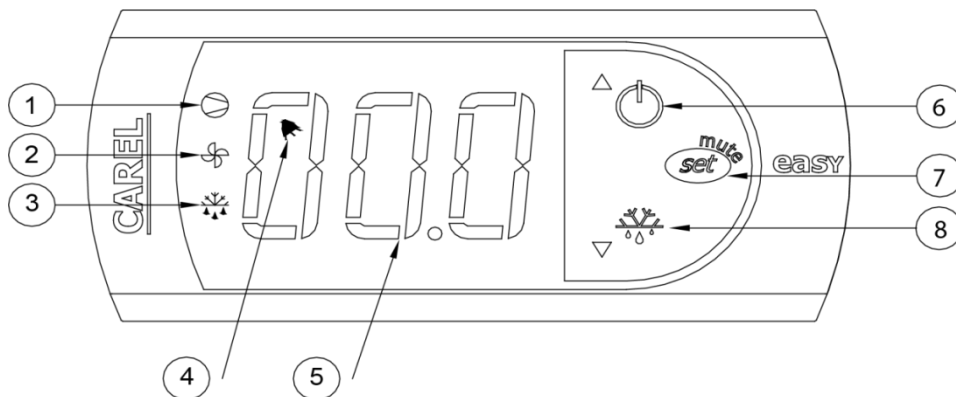

**WHAT DO DIODES ON CONTROL PANEL SIGNIFY**

**Diode 1 - Compressor:** This symbol is visible when the compressor is working. It is blinking when compressor actuation is delayed by security procedure. It blinks in the following cycle: two blinks – pause, when the constant working mode is activated.

**Diode 2 - Ventilator:** This symbol is visible when evaporator ventilators are turned on. It blinks when the actuation of the ventilators is delayed by external disengagement or when another procedure is in progress.

**Diode 3 - Defrosting:** This symbol is visible when the defrosting function is activated. It blinks when the actuation is delayed by external disengagement or when another procedure is in progress.

**Diode 4 - Alarm:** This symbol is visible when the alarm is activated.





**Diode 5 - Current temperature** inside the equipment is displayed (decimal places displayed after the comma).

**Diode 6 – On/Off Switch:** Pressing this button alone: for more than 3 sec. switch On/Off, **Pressing with other buttons:** pressed together with 8 activities/deactivates the continuous cycle.

**Diode 7 – Set/ Mute:** **Pressing this button alone:** 1 sec. displays /sets the set point, more than 3 sec. accesses the parameter setting menu (enter password 22), mutes the audible alarm (buzzer), **Start Up:** hold the set/mute button for 1 sec. RESET current EY set / Pressed together (7 and 8) activate parameter reset procedure.

**Diode 8 – Defrost:** **Pressing this button alone:** more than 3 sec. activates/deactivates the defrost. **Pressing with other buttons:** pressed together with 6 activates/deactivates the continuous cycle, **Start Up:** hold for 1 sec. displays firmware version.

**SETTING THE DESIRED TEMPERATURE**

- Press the set button  for 1 second leading value shall be displayed on the screen
- Increase or decrease the leading value by means of  and , until the desired value shall be obtained;
- Press the set button  once again in order to confirm the new value of the setting point.

**MANUAL INPUT OF THE DEFROSTING CYCLE**

Defrosting shall be released in an automatic mode. It is possible to force defrosting at any moment by pressing and holding the  defrost switch for minimum 5 seconds.

**Table 2 Table of alarms and signals**

alarm code	buzzer and alarm relay	LED	alarm description	reset
E0	active	ON	probe 1 error= control	automatic
E1	active	ON	probe 2 error= defrost	automatic
E2	active	ON	probe 3 error= condenser/product	automatic
EE	active	ON	unit parameter error	not possible
EF	active	ON	operating parameter error	manual
Ed	not active	ON	defrost ended by timeout	On first defrost ended correctly
CHt	active	ON	dirty condenser alarm	manual

**MODIFYING THE PARAMETERS**

**Parameter navigation**

The operating parameters, modifiable using the keypad, are divided into two types: frequent (type F) and configuration (type C). Access to the latter is protected by password (default= 22) to prevent accidental or unauthorized modifications.

**Accessing the type F parameters:**

- Press the SET button for more than 3 s (if there are active alarms, mute the buzzers). The display shows the parameter code 'PS' (password);
- Use the UP and DOWN buttons to scroll the parameters. The LED corresponding to the category of parameters will be on;
- Press SET to display the value associated with the parameter.
- Increase or decrease the value using the UP or DOWN button respectively.
- Press SET to temporarily save the new value and display the parameter again.
- Repeat the procedure for any other parameters that need to be modified.
- Press the SET button for more than 3 s to permanently save the parameters and exit the parameter setting procedure.

**Table 3 Table of easy compact parameters**

Par.	Description	Def.	UOM.	Min	Max
St	set point	1	°C	r1	r2
PS	password	22	-	0	99
/2	probe measurement stability	4	-	1	15
/4	select probe displayed	1	-	1	3
/5	select °C/°F	0	-	0(°C)	1(°F)
/6	disable decimal point	0	-	0	1
/C1	probe 1 offset	0.0	°C	-50.0	50.0
/C2	probe 2 offset	0.0	°C	-50.0	50.0
/C3	probe 3 offset	0.0	°C	-50.0	50.0
rd	control differential	3.0	°C	0	19.0
r1	minimum set point value	0.0	°C	-50.0	r2
r2	maximum set point value	15.0	°C	r1	99
r3	select direct/reverse operation	0	-	0	2
r4	night-time set point delta	3.0	°C	-50	50
c0	compressor and fan start delay on power-up	1	min	0	100
c1	minimum time between consecutive compressor starts	1	min	0	100
c2	minimum compressor off time	1	min	0	100
c3	minimum compressor on time	0	min	0	100

c4	compressor on time with duty setting	50	min	0	100
cc	continuous cycle duration	2	2	0	15
c6	temperature alarm bypass after continuous cycle	2	h	0	15
d0	type of defrost	0	-	0	4
d1	interval between defrosts	8	h	0	199
dt	end defrost temperature set point	12.0	°C	-50	130
dP	maximum defrost duration	60	min	1	199
d4	defrost when switching the instrument on	0	-	0	1
d5	defrost delay on power-up or when enabled by digital input	0	min	0	199
d6	freeze control temperature display during defrost	1	-	0	1
dd	dripping time	2	min	0	15
d8	alarm bypass time after defrost	1	h	0	15
d9	defrost priority over compressor protectors	0	-	0	1
d/	defrost probe reading (2)	-	°C	-	-
dC	time base	0	-	0	1
A0	alarm and fan temperature differential	2.0	°C	-20	+20
AL	absolute/relative temperature for low temperature alarm	0.0	°C	-50	+99
AH	absolute/relative temperature for high temperature alarm	0.0	°C	-50	+99
Ad	temperature alarm delay	0	min	0	199
A4	3rd input configuration	0	-	0	11
A7	digital input alarm delay	0	min	0	199
A8	enable alarm "Ed" (end defrost by timeout)	0	-	0	1
Ac	set point dirty condenser alarm	60	°C	-50	250
AE	dirty condenser alarm differential temperature	3.0	°C	0.1	20
Accd	dirty condenser alarm delay	0	min	0	250
H0	serial address	1	-	0	207
H1	AUX output configuration	0	-	0	2
H2	enable keypad	1	-	0	2
H4	disable buzzer	0	-	0	1
H5	ID code (read-only)	-1	-	1	+199
EZY	restore the Default settings	2	0	0	1

## 5. MAINTENANCE

- Do not use steel wool, abrasive cleaners, bleach or cleaners containing chlorine or sodium to clean the unit.
- Do not use pressure washer or water-jet to clean the unit.
- The unit should be cleaned right after unpacking and before turning on.
- The unit should be cleaned with warm water and mild soap.
- Devices with wheels cannot be used on uneven surfaces!

## 5.1 Cleaning and maintenance

- ***All maintenance services need to be performed after disconnecting the equipment from power supply!***
- ***Protect electric installation against any damage or water spillage.***
- ***Do not use water stream to clean the equipment, only a wet cloth.***
- ***Do not use any sharp objects to remove dirt!***

It is recommended to make a break in the operation **once a month** in order to clean the interior, naturally defrost the evaporator and clean the condenser.

It is essential to keep the condenser of the device clean. Dirt may hinder the heat exchange, causing an increase in electricity consumption and may cause damage of the compressor. In order to clean the condenser it is necessary to unscrew the sheet metal screws and pull the wind brace out of catch by lifting it up. Clean condenser lamellas with help of soft brush or paint brush. If the condenser is extremely dirty (blocking of lamellas), use a vacuum cleaner or compressed nitrogen to remove dirt from between lamellas.

**Figure 8 Cleaning the condenser**

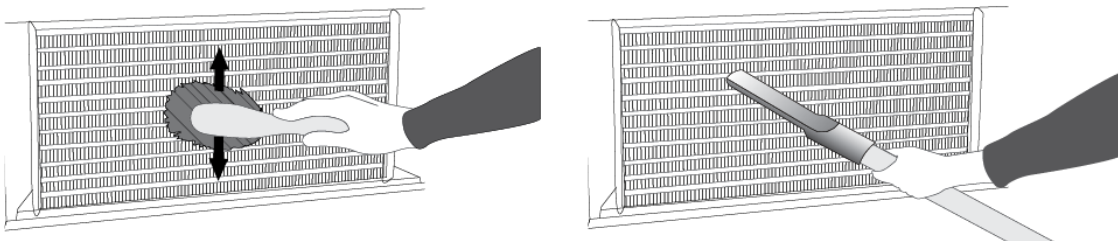

***The seller shall not be held responsible for the condenser damages in the case of non-observance of condenser cleaning instructions!***

***Door seal should be cleaned only with clean water, without any washing agents or chemicals and should be thoroughly dried. The seal cannot come in contact with grease or oils! Check the doors for proper closure during maintenance.***

***(Place a sheet of paper between the seal and the casing and close the door. The paper should resist when attempt to pull it out).***

*Elements of device can corrode when improper used and maintenance. To avoid that please follow the rules:*

- *Do not allow contact of the surface of the device with substances containing chlorine and / or baking soda in different varieties, which destroy the protective layer and components of the device (also includes various stainless steel)!*

## 6. SERVICE

### 6.1. Faults identification and repair

In case of any difficulties during actuation of the equipment or during its operation, please return to the chapters in this manual, which explain the performed operation. This aims to ensure the equipment is properly operated. If you still experience difficulties, the following might help you solve the problem.

**The equipment is not working... – Make sure that:**

- The equipment is connected to the power supply.
- Voltage and frequency in the network are compliant with those recommended by the manufacturer, 115V/60Hz.
- The main switch is turned on.
- Thermostat is turned on.

**The equipment is operating, but the light is off... – Make sure that:**

- Light switch is turned on.
- Lamp or starting switch of the equipment is not burnt.

**The equipment does not reach the proper temperature, the light is on... – Make sure that:**

- The main switch is on.
- Temperature setting on the thermostat is properly set.
- Thermostat works properly.
- The condenser is clean, if necessary – clean the condenser.
- Ambient temperature does not exceed 25°C.
- Enough time has passed for products to be cooled.
- Door of the unit close properly and whether the seal adheres to the body of the unit
- Ventilation holes are not blocked.

**Thermostat displays E0 or E1 or L0 or HI or EE or Ed or DF instead of temperature:**

- E0 – failure of temperature sensor inside the chamber – call authorized service.
- E1 – failure of evaporator sensor – call authorized service.
- L0 – low temperature alarm (lower than temperature range set within the equipment– call authorized service.
- HI – high temperature alarm – call authorized service.
- EE – internal defect of the regulator – call authorized service.
- Ed – maximum defrosting time exceeded.
- DF – defrosting in progress (this is not an alarm signal).

**The equipment is working too loud...– Make sure that:**

- The equipment is standing stably and properly levelled.
- Furniture adjoining the equipment does not vibrate when self-contained compressor is working.

**The equipment is working but the frame is not rotating... -Make sure that:**

- The frame rotation switch is on.
- Unit door is closed.

***Noises made by the operating device is normal. The units are equipped with ventilators, engines and compressors, which turn on and off automatically. Each compressor makes certain noises when operating. These sounds are made by the aggregate engine and by cooling agent flowing through the circuit. This noise constitutes a technical feature of cooling devices and does not signify equipment failure.***

***Steam precipitation on glass is normal in event of high relative air humidity exceeding 60% and does not require calling for service.***

## **6.2 Service**

### **IGLOO Refrigeration service**

**Telephone number:** 416-663-3051 or (toll free) 1-888-408-8819

**E-mail:** [service@igloo400.com](mailto:service@igloo400.com)

If after checking points described in chapter 6.1 “Faults identification and repair” the equipment still does not work properly,

Please contact Technical Service of the IGLOO Refrigeration.