

C2UDHP 3 Shelf

**HIGH PROFILE
OPENABLE FRONT GLASS
NON-REFRIGERATED PASTRY CASE**



C2UDHP3

Standard Features

- Non-refrigerated pastry case
- Side panels made of black/white coated steel
- Glass shelves with height and angle adjustment
- Bottom shelf made of black/white melamine
- Back sliding doors with combined glass
- Openable front glass with bending radius R20
- Each shelf includes LED lighting
- Device leveling legs

Options

- Multiple colors available
- Option of multiplexing
- Internal frame available in silver or gold

Metal element colours



Aluminum profile colours



Technical Drawing

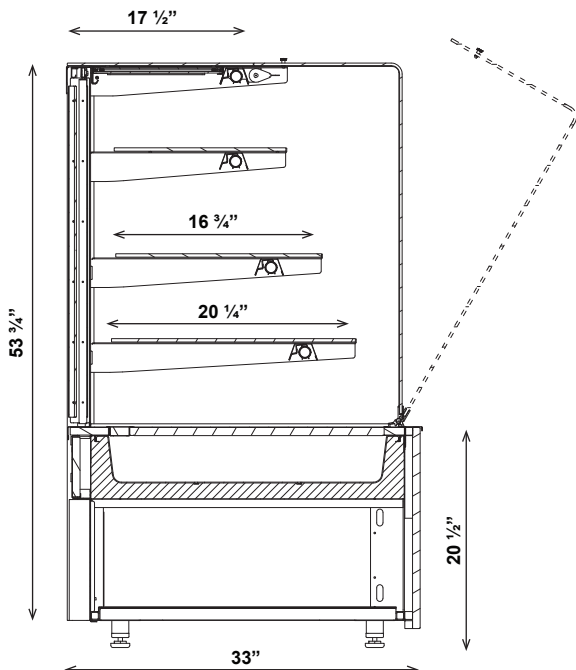

Dimensions

Model	Dimension W x D x H	Weight (lbs / kg)
C2UDHP2	24" x 33" x 53 3/4"	-
C2UDHP3	36" x 33" x 53 3/4"	-
C2UDHP4	51 1/2" x 33" x 53 3/4"	-
C2UDHP6	71 1/2" x 33" x 53 3/4"	-

*** Customizable options available**

*** Multiple sizes available**

Voltage

- C2UDHP2 : 115V / 1ph / 60 Hz / 2A, max. fuse: 15A
- C2UDHP3,4 : 115V / 1ph / 60 Hz / 3A, max. fuse: 15A
- C2UDHP6 : 115V / 1ph / 60 Hz / 6A, max. fuse: 15A

* Specifications are subject to change without notice.

**All measurements are approximates.

***All equipment are designed to operate in a controlled environment below 75°F (+24°C) temperature and HR 55% relative humidity.