

C2URHP 3 Shelf

HIGH PROFILE OPENABLE FRONT GLASS REFRIGERATED PASTRY CASE



C2URHP3

Standard Features

- Internal cooling aggregate
- Dynamic cooling (ventilated) system
- Ecological polyurethane foam insulation
- Back sliding doors with combined glass
- Openable front glass with bending radius R20
- Front glass warm air blast
- Each shelf includes LED lighting
- Leveling legs
- Automatic defrost system
- Automatic condenser vaporization system
- Electronic temperature controller with digital display
- Glass shelves with height and angle adjustment

Options

- Multiple colours available
- Option of multiplexing
- Internal frame available in silver or gold
- Remote compressor

Metal element colours

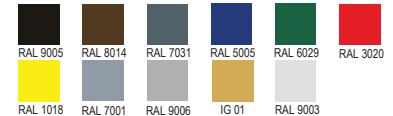

Aluminum profile colours

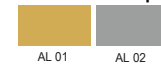

Technical Drawing

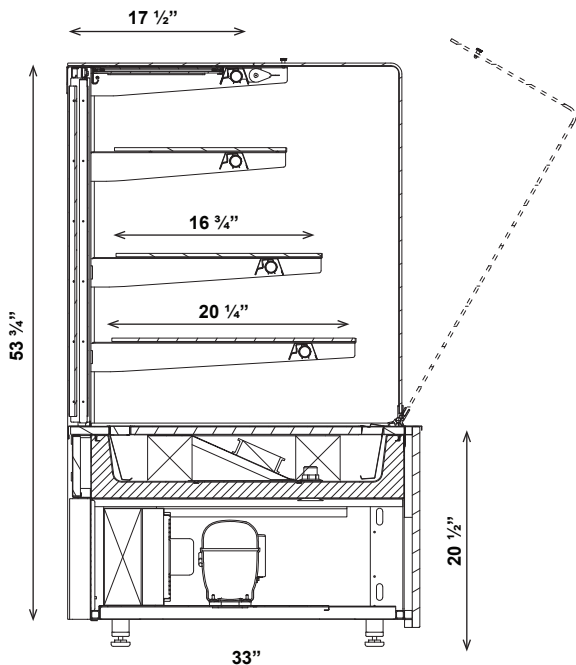

***All equipment are designed to operate in a controlled environment below 75°F (+24°C) temperature and HR 55% relative humidity.

Dimensions

Model	Dimension W x D x H	Weight (lbs / kg)
C2URHP2	24" x 33" x 53 3/4"	
C2URHP3	36" x 33" x 53 3/4"	
C2URHP4	51 1/2" x 33" x 53 3/4"	
C2URHP6	71 1/2" x 33" x 53 3/4"	

* **Customizable options available**

* **Multiple sizes available**

Voltage

- C2URHP2,3 : 115V / 1ph / 60 Hz / 8A, max. fuse: 15A
- C2URHP4 : 115V / 1ph / 60 Hz / 12A, max. fuse: 15A
- C2URHP6 : 115V / 1ph / 60 Hz / 15A, max. fuse: 20A

* Specifications are subject to change without notice.

**All measurements are approximates.