

salva



modular NXM-1002-P1 S730 Advance

FEATURES

Electrical polyvalent oven for trays formed by one independent chamber apilable that allow to mount the oven so that it adapts to the current and future needs of the client.

STRUCTURE

■ Oven door

Double low-emissivity glass.

The glass is easy to replace and to clean.

Reinforced insulation for high temperatures (400°C)

■ Allogenic lighting

■ Adapted for Pizza

Ceramic heating elements

Cemented Pizza Stone floor.

■ Advance Control Panel

It allows adapting the program and the regulation of the ceiling, floor and front heating elements.

Optimization of heat loss with an independently controlled front heat curtain.

NEWS

Lower consumption ■

The POWER MASTER CONTROL system allows it to operate 33% below nominal power.

Better baking ■

The system of electrical resistances crossing the ceramic bricks, the heart of the SALVA modular oven, ensures excellent baking.

More programs ■

The new control panel has up to 100 different programs allowing different baking phases.

Connectivity ■

The E-FUTURE control panel means it can connect to the internet via the SALVA LINK program and be controlled from any mobile device.

Temperature ■

The cooking temperature is up to 400°C due to the additional reinforcement of the baking chamber

OVEN COMPOSITION AND DETAILS

1 Top module

Essential.
Height: 165 mm.

2 Base

Essential.
Height: 150 mm.

4 Support NXM-730/02

Legs height: 730 mm.
Wheels height: 200 mm.

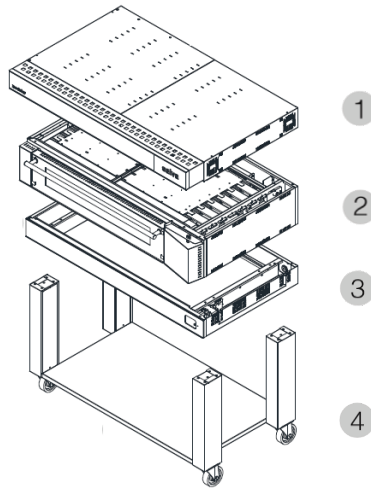

2

One modules NXM-P1
Height: 315 mm/module.
Capacity: 12 pizzas Ø 30cm

Total kW	V	A	Hz	BOCPD
8.3 kW 3Ph+G	204-240	21.6	50/60	30 Amp.

Weight: 325Kg

INSTALLATIONS IN DETAIL

A Baking chamber fumes chimney

It is recommendable to use a standard independent insulated damper of 200 mm (6.9") inside diameter.

B Electric power supply

The electrical connection should be performed by authorized professionals, following the rules in force in each country.

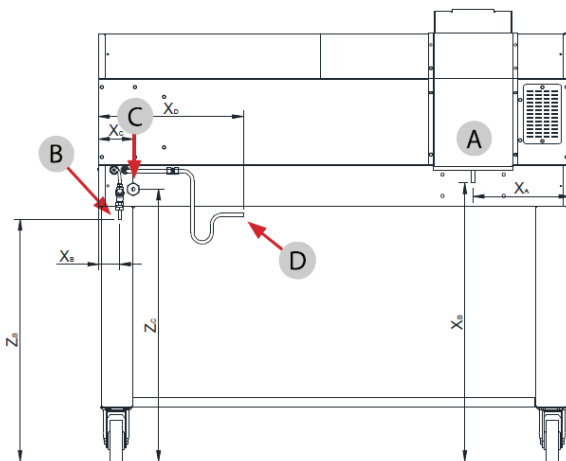

	X	Y	Z
A Baking chamber fumes chimney	353,5	73	1015,5
B Electric power supply	126	-	993

GENERAL DIMENSIONS

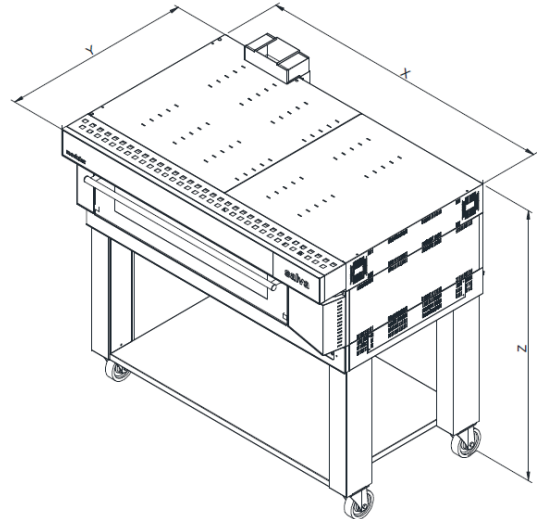

X	Y	Z
1461 mm	1331 mm	1560 mm

Facilities location (mm) ■

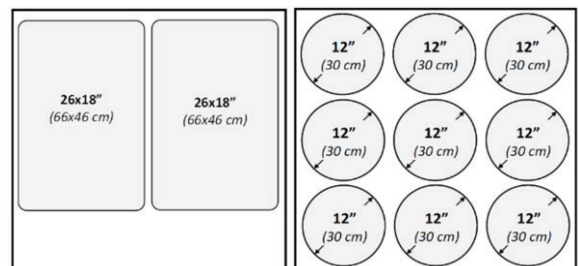

Surface per deck: 0,87 m²

Capacity per deck: 2 tray (66x46 or 75x45)
9 pizzas 30 cm Ø