

### 60M 3 Shelves, Self Contained

### LOW PROFILE MULTI-DECK OPEN MERCHANDISERS



60M4

#### Standard features

- Self contained
- Dynamic cooling
- Base, front and sides panel made of painted metal
- Stainless steel finished insides
- Price strips - color selection available
- LED lights on all shelves
- Night curtain
- Display shelves (height/angle adjustable)
- Adjustable legs
- Dynamic cooling
- Electronic programmable thermostat
- Digital temperature display
- Auto defrost

#### Options

- Base, front & sides metal color options available
- All stainless steel finish available
- Possibility of multiplexing
- Remote compressor

#### Plastic price stripes colors

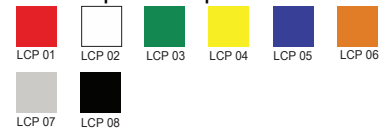

#### Metal elements colors



#### Technical Drawings

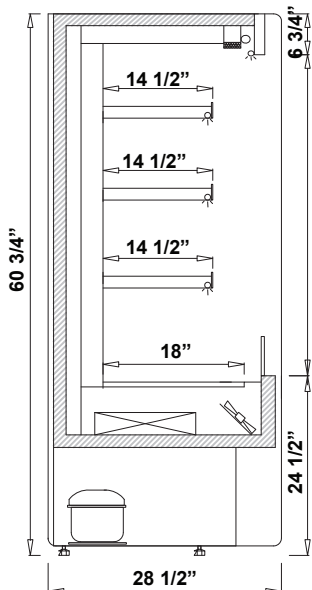

#### Dimensions

Model	Dimension W x D x H	Weight (lbs / kg)
60M3	39 1/2" x 28 1/2" x 60 3/4"	—
60M4	51 1/2" x 28 1/2" x 60 3/4"	—
60M5	63 1/2" x 28 1/2" x 60 3/4"	—
60M6	75 1/2" x 28 1/2" x 60 3/4"	—
60M8	100" x 28 1/2" x 60 3/4"	—

*\* Endless lineup, any length available*

#### Voltage

- 60M3,4 : 115V , 1ph , 60 Hz , 15A, max. fuse: 20A
- 60M5~8 : 115V/ 220V , 1ph , 60 Hz , 11A, max. fuse: 15A

\* Specifications are subject to change without notice.

\*\*All measurements are approximates.

\*\*\*All equipment designed to operate in controlled environment below 75°F (+24°C) temperature and HR 55% relative humidity.