

BSCD90-IN

Curved Glass, Self Contained

**INWARD REFRIGERATED CORNER
DELI/MEAT/CHEESE/SALAD
CASE MATCHING W/ BSC**

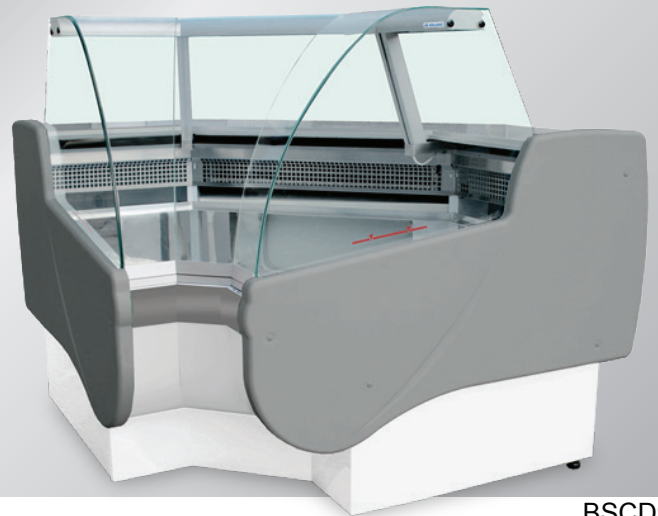

BSCD90-IN

Standard Features

- Curved front glass
- Granite work counter
- Interior LED lighting
- Additional refrigerated under-shelf storage cabinet
- ABS sides - (off-white)
- Painted white front and base
- Front bumper - different colours available
- Digital temperature display
- Gravity cooling system
- Automatic defrost cycle
- Automatic condensation disposal
- Front glass defogging system

Options

- Remote compressor
- Stainless steel base and front
- Possibility of multiplexing merchandiser
- Self-served units upon request
- Variety of finished colours

Metal element colours



Plastic bumper colours

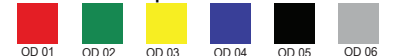

Plastic side colours

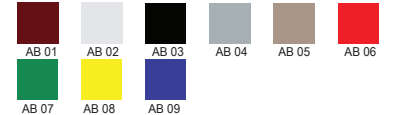

Granite colours



Aluminum profile colours



Dimensions

Model	Dimension W x D x H	Weight (lbs / kg)
BSCD90-IN	52 3/4" x 52 3/4" x 48 1/2"	386 / 175

Technical Drawings

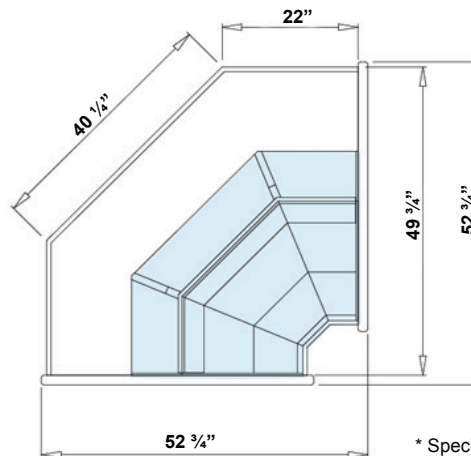
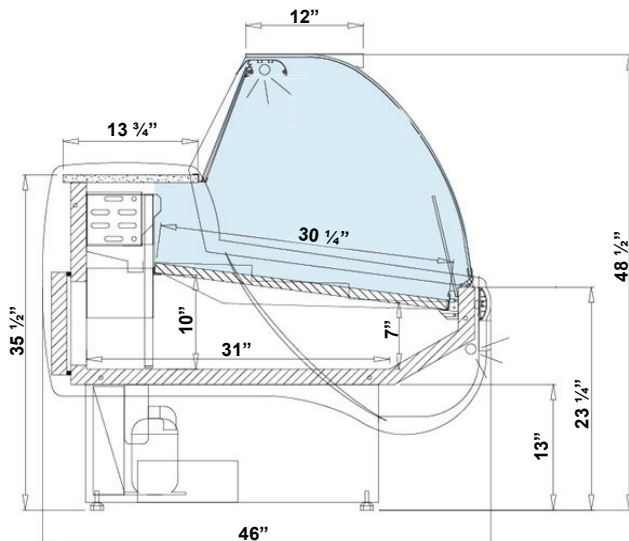

Voltage

- 115V | 1ph | 60 Hz | 6A,
max. fuse: 15A

* Specifications are subject to change without notice.

**All measurements are approximates.

***All equipment are designed to operate in a controlled environment below 75°F (+24°C) temperature and HR 55% relative humidity.