

C3URP 2 Shelf

STRAIGHT FRONT & SIDES DOUBLE GLASSES REFRIGERATED PASTRY CASE



C3URP4

Standard Features

- Straight front and sides double glasses
- Internal cooling aggregate
- Dynamic cooling (ventilated)
- External housing made of black/white coated steel
- Ecological polyurethane foam insulation
- Bottom shelf made of black/white melamine
- Back sliding doors with combined glass
- Front glass warm air blast
- Top and front frame LED illumination
- Device leveling legs
- Automatic defrost
- Automatic condenser vaporization
- Electronic temperature controller with digital display
- Glass exposition shelves with height and angle adjustment

LED lamps

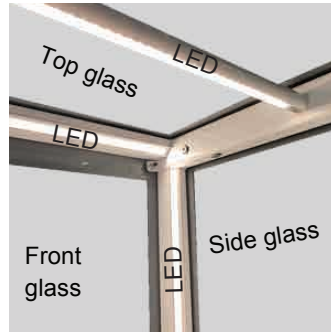

Options

- Other colors available

Metal elements colors



Technical Drawing

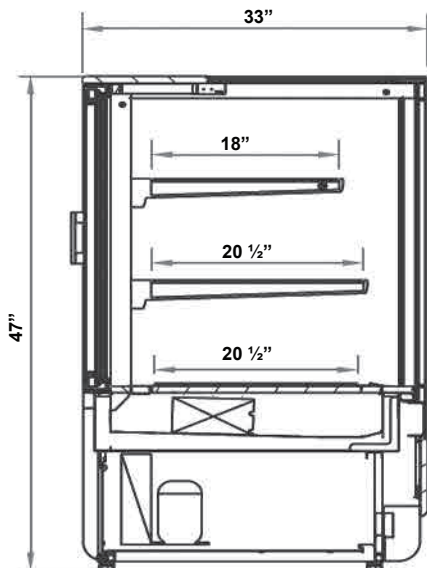

Dimensions

Model	Dimension W x D x H	Weight (lbs / kg)
C3URP3	37" x 33" x 47"	-
C3URP4	53" x 33" x 47"	-

Voltage

- C3URP3 : 115V / 1ph / 60 Hz / 8A, max. fuse: 15A
- C3URP4 : 115V / 1ph / 60 Hz / 12A, max. fuse: 15A

* Specifications are subject to change without notice.

**All measurements are approximates.

***All equipment designed to operate in controlled environment below 75°F (+24°C) temperature and HR 55% relative humidity.