

COCJT

Trend Counter W/ Front Glass

**CASH COUNTER
MATCHING WITH
JM RTP MODEL**



COCJT41

Standard Features

- Painted enamel finish
- Matching front with JM RTP/JMDTP model bakery display cases
- Gold- painted internal frame
- Curved movable front glass
- Top LED lighting system
- Device leveling legs

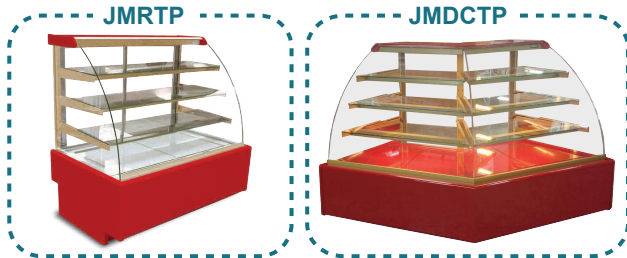

Options

- Other colors available
- Internal frame painted silver or gold
- Wood, stainless steel or granite top
- Custom made upon customers request

Trend colors

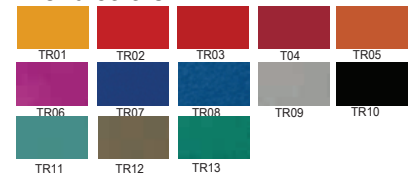

Aluminum profiles colors



Dimensions

Model	Dimension W x D x H	Weight (lbs / kg)
COCJT31	31" x 34" x 36 1/2"	242 / 110
COCJT41	41 3/4" x 34" x 36 1/2"	264 / 120
COCJT51	51 1/4" x 34" x 36 1/2"	286 / 130
COCJT67	67" x 34" x 36 1/2"	352 / 160

Technical Drawings

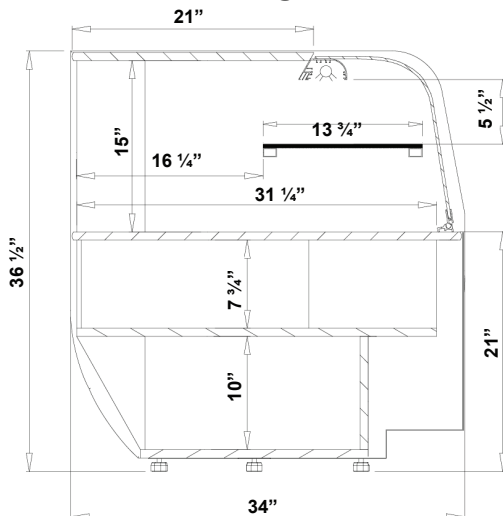

***All equipment designed to operate in controlled environment below 75°F (+24°C) temperature and HR 55% relative humidity.

Voltage

- 115V / 1ph / 60 Hz / 1A, max. fuse: 15A

* Specifications are subject to change without notice.

**All measurements are approximates.