

## CHECK OUT COUNTERS

### COCS

### CASH COUNTER MATCHING WITH SAND MODEL



COCS31

### Standard Features

- Grey granite worktop (thickness 3/4")
- Matching front with SAND model refrigerated display cases
- External housing made of white coated steel
- Device leveling legs
- Movable drawer
- Socket

#### Metal elements colors



#### Plastic sides colors

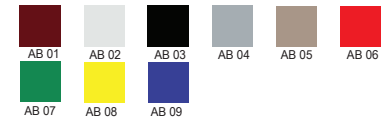

#### Plastic bumpers colors

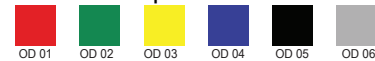

#### Granite colors



#### Aluminum profiles colors



### Options

- Other colors available
- Custom made upon customers request

### Technical Drawing

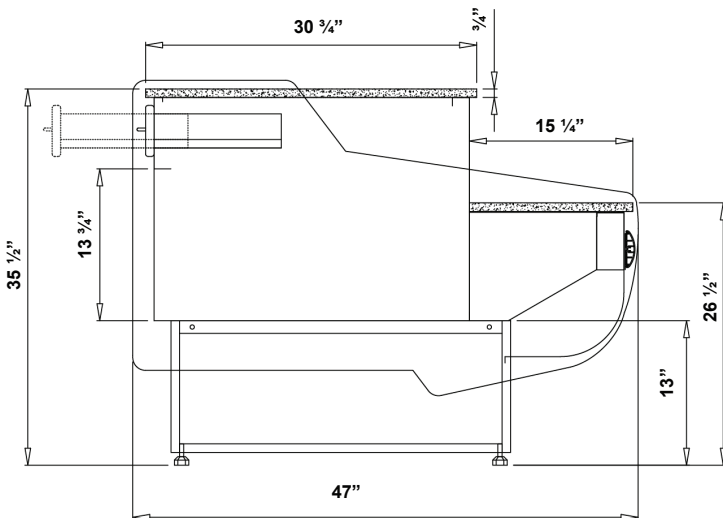

### Dimensions

| Model  | Dimension W x D x H     | Weight (lbs / kg) |
|--------|-------------------------|-------------------|
| COCS19 | 19" x 47" x 35 1/2"     | 101.4 / 46        |
| COCS23 | 23" x 47" x 35 1/2"     | 123.5 / 56        |
| COCS27 | 27" x 47" x 35 1/2"     | 152.1 / 69        |
| COCS31 | 31" x 47" x 35 1/2"     | 176.4 / 80        |
| COCS35 | 35" x 47" x 35 1/2"     | 207.2 / 94        |
| COCS38 | 38 3/4" x 47" x 35 1/2" | 229.3 / 104       |
| COCS42 | 42 3/4" x 47" x 35 1/2" | 242.5 / 110       |
| COCS46 | 46 3/4" x 47" x 35 1/2" | 277.8 / 126       |
| COCS50 | 50 1/2" x 47" x 35 1/2" | 297.6 / 135       |
| COCS54 | 54 1/2" x 47" x 35 1/2" | 330.7 / 150       |
| COCS58 | 58 1/2" x 47" x 35 1/2" | 354.9 / 161       |
| COCS62 | 62 1/2" x 47" x 35 1/2" | 381.4 / 173       |

### Voltage

• N/A

\* Specifications are subject to change without notice.

\*\*All measurements are approximates.

\*\*\*All equipment designed to operate in controlled environment below 75°F (+24°C) temperature and HR 55% relative humidity.