

SUMWD Wooden Case Straight Glass, Self Contained

REFRIGERATED DELI/MEAT/CHEESE/SALAD CASE



SUMWD5

Standard features

- Cherry wood finish
- Glass top with straight front glass
- Granite worktop
- Lamp with LED light
- Additional refrigerated under-shelf storage cabinet
- Insulated ABS side panels
- Display area (stainless steel)
- Digital temperature display
- Gravity cooling system
- Automatic defrost cycle
- Automatic condensation disposal
- Front glass warm air blast
- Night blinds made of plexi glass
- Device leveling legs
- Automatic defrost system
- Flat insert

Options

- Remote compressor
- All stainless steel base and front
- Possibility of multiplexing merchandiser
- Self-served units upon request
- Variety of wood finishes
- Steps insert

Wood veneer

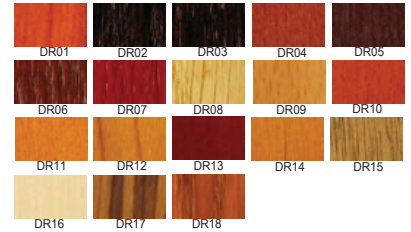

Granite colours



Aluminum profile colours



Technical Drawings

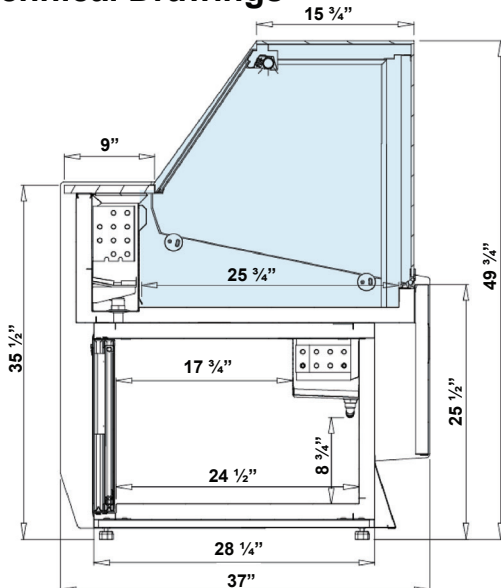

***All equipment are designed to operate in a controlled environment below 75°F (+24°C) temperature and HR 55% relative humidity.

Dimensions

Model	Dimension W x D x H	Weight (lbs / kg)
SUMWD3	41 3/4" x 37" x 49 3/4"	358 / 160
SUMWD5	59" x 37" x 49 3/4"	454 / 206
SUMWD6	80 1/2" x 37" x 49 3/4"	569 / 258
SUMWD8	99 1/4" x 37" x 49 3/4"	706 / 320

* Customizable options available

* Multiple sizes available

Voltage

- SUMWD3,5,6 : 115V | 1ph | 60 Hz | 8A, max. fuse: 15A
- SUMWD8 : 115V | 1ph | 60 Hz | 10A, max. fuse: 15A

* Specifications are subject to change without notice.

**All measurements are approximates.