



Instruction Manual

Pastry Display Cases

Models: CURP series



CURLP



CURP



CURHP

124 Norfinch Dr. Toronto, ON. M3N 1X1
Tel : 416-663-3051 Fax : 416-663-5793
Toll Free : 1-888-408-8819

 **IGLOO**
REFRIGERATION LTD.

Contents

Contents	2
1 UNLOADING	3
2 PROPERTIES OF THE UNIT.....	3
2.1. Purpose	3
2.2. Description of the unit.....	3
2.3. Technical data.....	4
3. PREPARING THE DEVICE FOR START UP	5
3.1. Installation requirements	5
3.2. Unit Location	5
3.3. Connection and start-up.....	6
4. UNIT START UP	8
4.1. Temperature regulation	9
5. MAINTENANCE	12
5.1 Cleaning and maintenance	12
6. SERVICE.....	14
6.1. Faults identification and repair	14
6.2 Service.....	15

List of Figures

Figure 1 CURP.....	4
Figure 2 placing the hooks in the frame.....	6
Figure 3 Hook height control.....	7
Figure 4 Assemble of glass elements	7
Figure 5 Control panel	8
Figure 6 “Carel” thermostat control panel.....	9
Figure 7 Manner of assembling/pulling out the blow in and suction.....	12
Figure 8 Cleaning the condenser	13

List of Tables

Table 1 Technical data	4
Table 2 Table of alarms and signals	10
Table 3 Table of easy compact parameters.....	11

1 UNLOADING

The unit should be transported in vertical position and properly secured and packed.

2 PROPERTIES OF THE UNIT

2.1. Purpose

“CURP” series display cases are universal cooling devices that are aimed to display and are used for short-term storage for confectionery goods (such as cakes, cookies, desserts... etc.) in temperature between +1°C and +4°C with ambient temperature between +15°C and +25°C and relative air humidity up to 55%, depending on the environment and the location of the unit.

2.2. Description of the unit

“CURP” series display cases have a dynamic cooling system. All units are equipped with automatic condensate evaporation and automatic defrosting. The electronic thermostat cooperates module to monitor and send signals when the temperature inside the equipment gets too low or too high. They can be supplied with self-contained or remote compressors. Glass shelves fixed on the frame make the exhibit part of display cases. The height and angle of the shelves are adjustable. These display cases use energy-saving LED lighting. Our equipment is manufactured in accordance to modern technologies and has all certificates required by law.

The description in this box signifies important information for user security and for proper operation of the device.

Figure 1 CURP

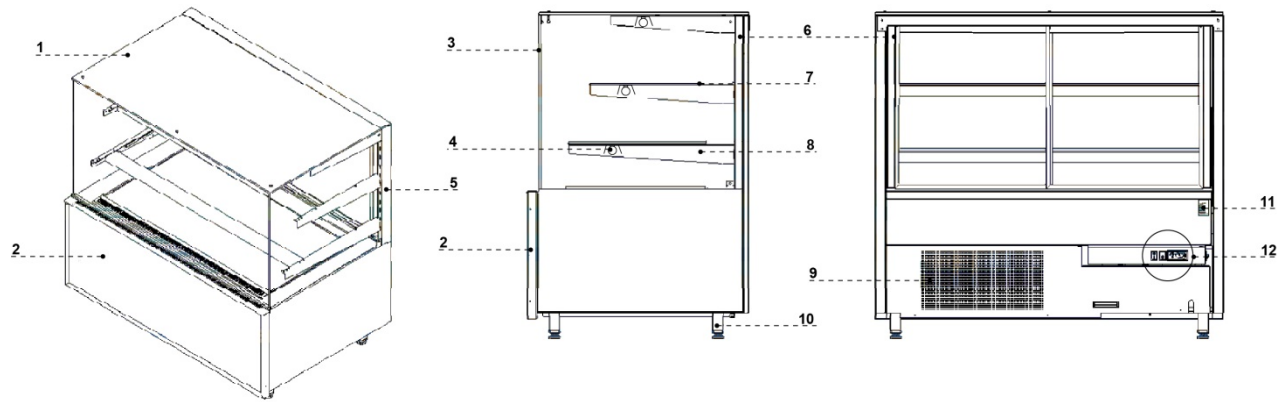

- 1 – Upper glass shelf
- 2 – Front panel
- 3 – Straight front glass
- 4 – LED lamp
- 5 – Inner frame (made of metal plates)
- 6 – Sliding doors (CURP3 and CURP4) or swing door (CURP2)
- 7 – Display glass shelf
- 8 – Shelf hook for glass shelf (height/angle adjustable)
- 9 – Condenser cover (DO NOT BLOCK air louver!!!)
- 10 – Leveling legs
- 11 – Serial plate
- 12 – Control panel (thermostat, switches)

Other CURP series

CURLP:1 Shelf

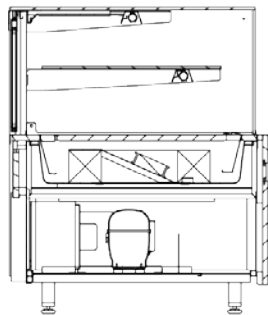

CURHP:3 Shelves

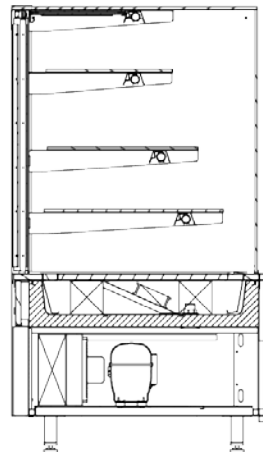

2.3. Technical data

Table 1 Technical data

Model	Voltage [V/Hz/Ph]	Rated Current [A]	Max shelf load [lbs/kg]	Weight [lbs/kg]
CURP2	115/60/1	8 (max.fuse:15)	22/10	198/90
CURP3	115/60/1	8 (max.fuse:15)	22/10	308/140
CURP4	115/60/1	12 (max.fuse:15)	22/10	397/180
CURLP2	115/60/1	8 (max.fuse:15)	22/10	-
CURLP3	115/60/1	8 (max.fuse:15)	22/10	-
CURLP4	115/60/1	12 (max.fuse:15)	22/10	-
CURHP2	115/60/1	8 (max.fuse:15)	22/10	-
CURHP3	115/60/1	8 (max.fuse:15)	22/10	-
CURHP4	115/60/1	12 (max.fuse:15)	22/10	-

3. PREPARING THE DEVICE FOR START UP

The unit must be properly installed and located in accordance with the installation instructions before it is used.

3.1. Installation requirements

- Always use a dedicated circuit with the amperage stated on the unit.
- Plug into an outlet designed for the plug.
- Do not overload the circuit.
- Do not use extension cords.
- Never use adapters.
- Never plug in more than one unit per electric circuit.
- If in doubt, call an electrician.

IGLOO will not warranty any equipment that is connected to an extension cord or adapter plug.

The equipment may be turned on after confirmation of the fire protection efficiency with results of measures performed according to binding regulations!

■ NEMA Plugs

IGLOO refrigeration uses this type of plugs. If you do not have the right outlet have a certified electrician install the correct power source.



115/60/1
NEMA-5-15R

3.2. Unit Location

- Remove cardboard angles and protective foil.
- Install the unit on a strong and leveled surface.
- To ensure proper operation of the unit, it must be leveled from front to back and left to right.
- Unit may malfunction if improperly leveled.
- Be sure there is sufficient ventilation around the entire unit.
- Select a location away from heat and moisture generating equipment.
- Avoid installation in a high ambient or humid location.
- High ambient temperatures will cause the compressor to overwork.
- Humidity may cause rust, condensation around glass or stainless steel and decrease the efficiency of the unit.

3.3. Connection and start-up

- Unpack the equipment.
- Place the unit on an even and hard base. Then level the unit with the levelling legs.
- Remove the protection foil from display case elements.
- To securely transport the equipment, the unit may be shipped partially disassembled. If the user received the unit partially disassembled, perform the following operations:
 1. Place hooks in frame rails. (Figure 2)
 2. Install the glass elements in this order:
 - Install glass sides to the rack. (Figure 4/3)
 - Mount the front glass pane in the pane grip (Figure 4/4) and attach to glass sides using 3-sided angle. (Figure 4/6)
 - Mount the upper glass shelf. (Figure 4/1)
 - Mount glass shelves on the inner surface and on the rack (Figure 4/12). The shelves should be placed on silicone elements (Figure 4/13) to prevent glass elements from moving.
- The equipment should be cleaned right after unpacking and before turning it on. The unit should be cleaned with warm water not exceeding 40°C with a neutral detergent. For washing and cleaning the equipment, it is prohibited to use products containing chlorine and sodium varieties, which destroy the protective layer and components of the equipment! Any residue of adhesives or silicone on metal elements should be removed only with extraction naphtha (not applicable to items made of plastic). Do not use other organic solvents.

When cleaning the unit, do not use water jet. The unit should be cleaned with a moist cloth.

After installation of the equipment at the destination location it should be left to rest for at least 2 hours before turning it on (for devices with built-in compressor) to set the level of refrigerant in order to prevent problems with starting up.
WARNING: Keep out the cooling circuit from damage!

- Turn on the main switch. (Figure 5/1)
- The temperature on the thermostat control panel is PRE SET. (Figure 5/3)
- Turn on the light switch. (Figure 5/2)

Figure 2 placing the hooks in the frame

- 1 – Vertical post of the internal frame
- 2 – Hook mounting holes
- 3 – Hook (adjustable to three different angles)

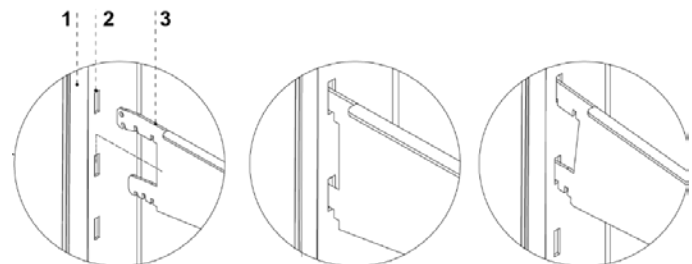

Hook on angle

Figure 3 Hook height control

- 1 – Hook
- 2 – Protective pipe covering lamp cord
- 3 – PVC profile hiding the vertical frame post

When changing the height position of the hook, draw the PVC profile aside slightly and pull the protective pipe to the desired position. Next remove the hook from the rack and place it in the suitable position and at the suitable angle.

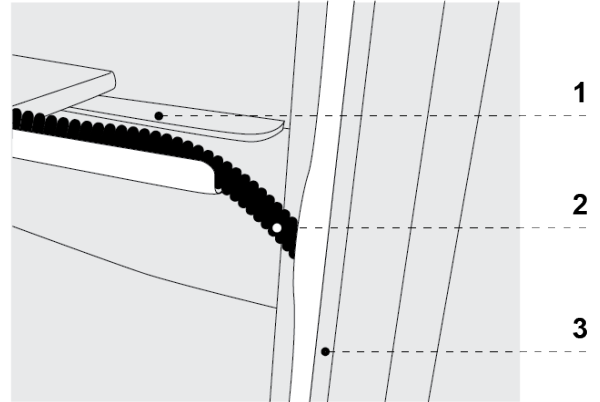

Figure 4 Assemble of glass elements

- 1 – Upper glass shelf
- 2 – Front glass pane
- 3 – Glass side
- 4 – Front glass pane grip
- 5 – Two sided angle for mounting of glass panes (to CURP4– connecting the middle part of the front glass with the upper glass shelf)
- 6 – Three-sided angle for mounting of glasses (for connecting the front glass with the glass side)
- 7 – Acorn nut of the screw
- 8 – Silicon pad
- 9 – Plasticizer pad
- 10 – Screw
- 11 – Inner frame
- 12 – Display glass shelves (of the frame)
- 13 – Bumper pads
- 14 – Inner surface

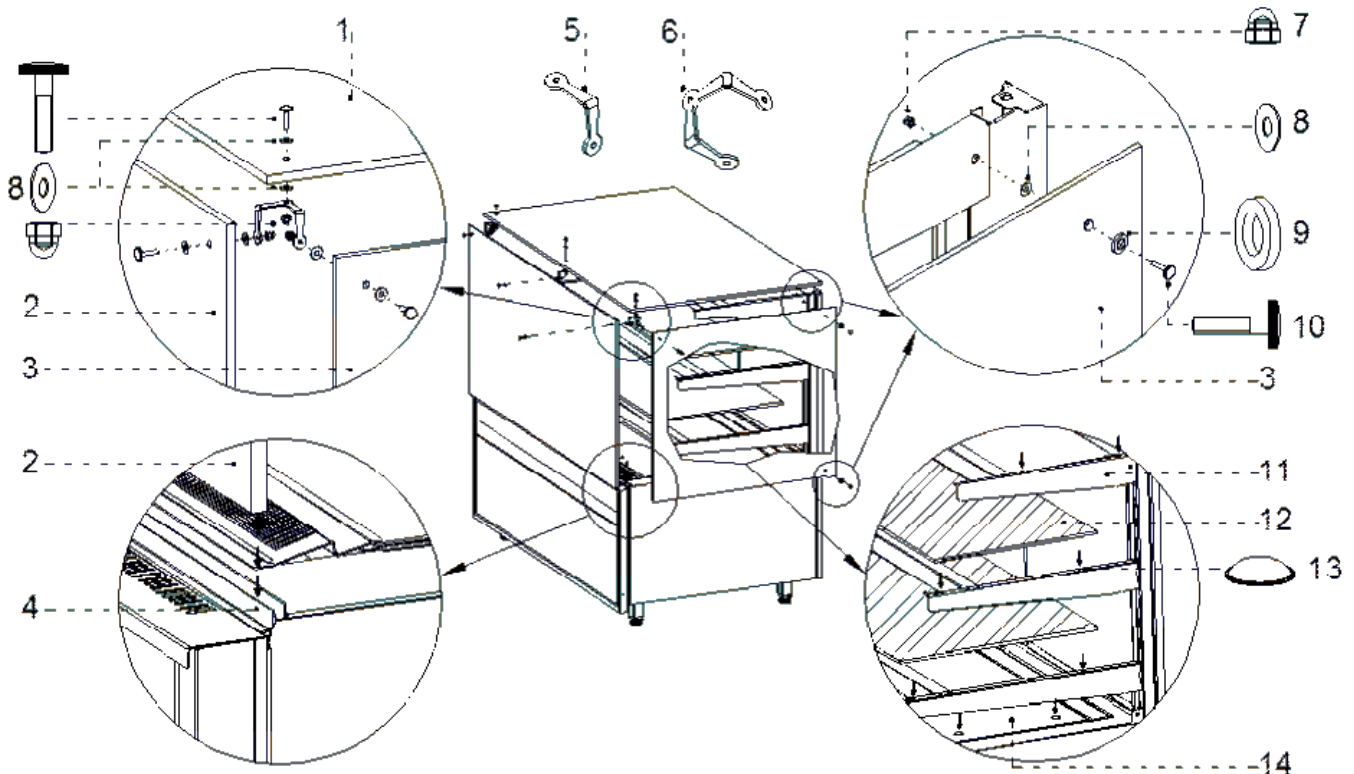
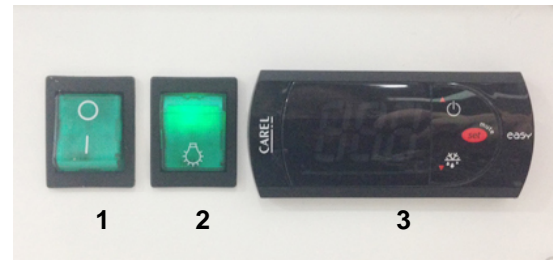

Figure 5 Control panel

- 1 – Main switch (turns on/off the unit)
- 2 – Light switch
- 3 – Thermostat (temperature regulator) panel
(Service details in Chapter 4)



4. UNIT START UP

Temperature of the cooled space and aggregate operating cycle may fluctuate. This depends on numerous factors, such as amount and temperature of products placed in the device and temperature of the surroundings. The equipment should be placed in a dry and well-ventilated place, ensuring proper air exchange (distance between the wall and the equipment– min. 10cm), out of sunlight, kept far from heat sources and devices enforcing air flow (ceiling and portable ventilators, blow-in heaters). The equipment functions properly in a room, where temperature falls within appropriate climatic class. The operation of the equipment may worsen when operates outside the stated temperature range.

Remarks and indications

- ***The display case has to be properly levelled, which will prevent noisy corking of the equipment and shall ensure proper water (condensate) outflow during defrosting.***
- ***After transporting the equipment, wait about 2 hours before starting up the unit.***
- ***To ensure proper conditions for the stored products, do not load the shelves completely. Ensure even load of shelves and not to exceed the maximum load.***
- ***The first filling of shelves should be performed after the unit reached desired cooling temperature. This principle should also be observed after long pause in the operation.***
- ***Do not block any ventilation holes, which would hamper circulation of the cooled air. It is also necessary to ensure proper airflow around the equipment.***
- ***Keep the condenser clean. Impurities may lead to overheating of the compressor and may result in damage, which is not covered by warranty.***
- ***Do not use electric devices inside the product storing chamber.***
- ***Avoid unnecessary opening of the doors and leaving them open for a longer period of time.***

4.1. Temperature regulation

The thermostat is to obtain the set temperature within the equipment and maintain it within the determined temperature ranges. The manufacturer enters all settings of temperature regulators required for normal functioning of the equipment. Before primary actuation the user should control and possibly set the required temperature inside the equipment on the control panel.

Digital display – displays the current temperature inside the equipment.

It is forbidden to interfere with systemic parameters of the thermostat, as this can lead to serious consequences, including the damage of the cooling unit!

Figure 6 “Carel” thermostat control panel

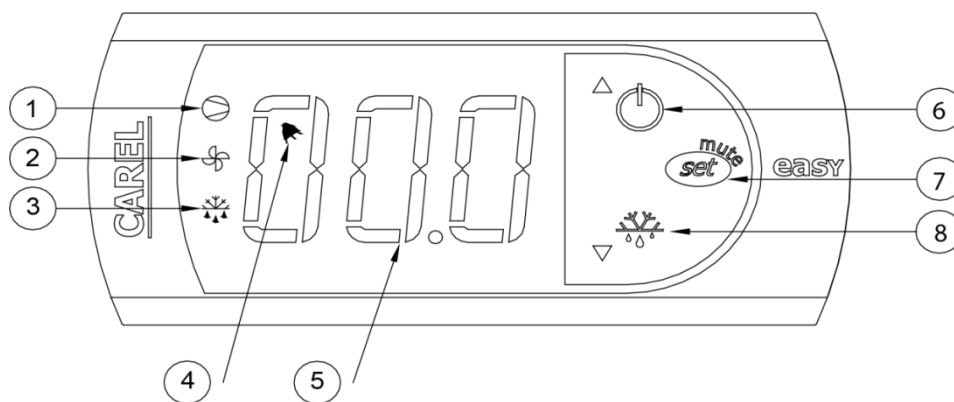

QuickFinder for CAREL

WHAT DO DIODES ON CONTROL PANEL SIGNIFY

Diode 1 - Compressor: This symbol is visible when the compressor is working. It blinks when compressor actuation is delayed by security procedure. It blinks in the following cycle: two blinks – pause, when the constant working mode is activated.

Diode 2 - Ventilator: This symbol is visible when evaporator ventilators are turned on. It blinks when the actuation of the ventilators is delayed by external disengagement or when another procedure is in progress.

Diode 3 - Defrosting: This symbol is visible when the defrosting function is activated. It blinks when the actuation is delayed by external disengagement or when another procedure is in progress.

Diode 4 - Alarm: This symbol is visible when the alarm is activated.





Diode 5 - Current temperature: inside the equipment is displayed (decimal places displayed after the comma).

Diode 6 – On/Off Switch: Pressing this button alone: for more than 3 sec. switch On/Off, **Pressing with other buttons:** pressed together with 8 activates/deactivates the continuous cycle.

Diode 7 – Set/ Mute: Pressing this button alone: 1 sec. displays /sets the set point, more than 3 sec. accesses the parameter setting menu (enter password 22), mutes the audible alarm (buzzer), **Start Up:** hold the set/mute button for 1 sec. RESET current EY set / Pressed together (7 and 8) activate parameter reset procedure.

Diode 8 – Defrost: Pressing this button alone: more than 3 sec. activates/deactivates the defrost. **Pressing with other buttons:** pressed together with 6 activates/deactivates the continuous cycle, **Start Up:** hold for 1 sec. displays firmware version.

SETTING THE DESIRED TEMPERATURE

- Press the set button  for 1 second leading value shall be displayed on the screen
- Increase or decrease the leading value by means of  and , until the desired value shall be obtained;
- Press the set button  once again in order to confirm the new value of the setting point.

MANUAL INPUT OF THE DEFROSTING CYCLE

Defrosting shall be released in an automatic mode. It is possible to force defrosting at any moment by pressing and holding the  defrost switch for minimum 5 seconds.

Table 2 Table of alarms and signals

alarm code	buzzer and alarm relay	LED	alarm description	reset
E0	active	ON	probe 1 error= control	automatic
E1	active	ON	probe 2 error= defrost	automatic
E2	active	ON	probe 3 error= condenser/product	automatic
EE	active	ON	unit parameter error	not possible
EF	active	ON	operating parameter error	manual
Ed	not active	ON	defrost ended by timeout	On first defrost ended correctly
CHt	active	ON	dirty condenser alarm	manual

MODIFYING THE PARAMETERS

Parameter navigation

The operating parameters, modifiable using the keypad, are divided into two types: frequent (type F) and configuration (type C). Access to the latter is protected by password (default= 22) to prevent accidental or unauthorized modifications.

Accessing the type F parameters:

- Press the SET button for more than 3 s (if there are active alarms, mute the buzzers). The display shows the parameter code 'PS' (password);
- Use the UP and DOWN buttons to scroll the parameters. The LED corresponding to the category of parameters will be on;
- Press SET to display the value associated with the parameter
- Increase or decrease the value using the UP or DOWN button respectively;
- Press SET to temporarily save the new value and display the parameter again;
- Repeat the procedure for any other parameters that need to be modified;
- Press the SET button for more than 3 s to permanently save the parameters and exit the parameter setting procedure.

Table 3 Table of easy compact parameters for CURP, CURLP and CURHP

Par.	Description	Def.	UOM.	Min	Max
St	set point	2	°C	r1	r2
PS	password	22	-	0	99
/2	probe measurement stability	4	-	1	15
/4	select probe displayed	1	-	1	3
/5	select °C/°F	0	-	0(°C)	1(°F)
/6	disable decimal point	0	-	0	1
/C1	probe 1 offset	0.0	°C	-50.0	50.0
/C2	probe 2 offset	0.0	°C	-50.0	50.0
/C3	probe 3 offset	0.0	°C	-50.0	50.0
rd	control differential	3.0	°C	0	19.0
r1	minimum set point value	0.0	°C	-50.0	r2
r2	maximum set point value	15.0	°C	r1	99
r3	select direct/reverse operation	0	-	0	2
r4	night-time set point delta	3.0	°C	-50	50
c0	compressor and fan start delay on power-up	1	min	0	100
c1	minimum time between consecutive compressor starts	3	min	0	100
c2	minimum compressor off time	0	min	0	100
c3	minimum compressor on time	2	min	0	100
c4	compressor on time with duty setting	50	min	0	100
cc	continuous cycle duration	2	2	0	15
c6	temperature alarm bypass after continuous cycle	2	h	0	15
d0	type of defrost	0	-	0	4
d1	interval between defrosts	6	h	0	199
dt	end defrost temperature set point	12.0	°C	-50	130
dP	maximum defrost duration	30	min	1	199
d4	defrost when switching the instrument on	0	-	0	1
d5	defrost delay on power-up or when enabled by digital input	0	min	0	199
d6	freeze control temperature display during defrost	1	-	0	1
dd	dripping time	2	min	0	15
d8	alarm bypass time after defrost	2	h	0	15
d9	defrost priority over compressor protectors	0	-	0	1
d/	defrost probe reading (2)	-	°C	-	-
dC	time base	0	-	0	1
A0	alarm and fan temperature differential	2.0	°C	-20	+20
AL	absolute/relative temperature for low temperature alarm	0.0	°C	-50	+99
AH	absolute/relative temperature for high temperature alarm	0.0	°C	-50	+99
Ad	temperature alarm delay	0	min	0	199
A4	3rd input configuration	0	-	0	11
A7	digital input alarm delay	0	min	0	199
A8	enable alarm "Ed" (end defrost by timeout)	0	-	0	1
AC	set point dirty condenser alarm	60	°C	-50	250
AE	dirty condenser alarm differential temperature	3.0	°C	0.1	20
Acd	dirty condenser alarm delay	0	min	0	250
F0	enable evaporator fan control	0	-	0	1
F1	evaporator fan control set point	5.0	°C	-50	130
F2	stop evaporator fan if compressor off	0	-	0	1
F3	evaporator fan status during defrost	0	-	0	1
Fd	post-dripping time	2.0	min	0	15
H0	serial address	1	-	0	207
H1	AUX output configuration	0	-	0	2
H2	enable keypad	1	-	0	2
H4	disable buzzer	0	-	0	1

H5	ID code (read-only)	0	-	1	+199
EZY	restore the Default settings		0	0	1

5. MAINTENANCE

- Before you start Maintenance on the unit, Power it **OFF**.
- Do not use steel wool, abrasive cleaners, bleach or cleaners containing chlorine or sodium to clean the unit.
- Do not use pressure washer or water-jet to clean the unit.
- The unit should be cleaned right after unpacking and before turning it on.
- The unit should be cleaned with warm water and mild soap.
- Make sure to cover the fan motor to prevent moisture damage.
- Dore gaskets, shelves and supports should be cleaned on a regular basis.
- Fan blades and guards should be cleaned with a soft cloth.

5.1 Cleaning and maintenance

- **All maintenance services need to be performed after disconnecting the equipment from power supply!**
- **Protect electrical components against any damage or water spillage.**
- **Do not use water stream to clean the equipment, only a moist cloth.**
- **Do not use any sharp objects to remove dirt!**

Figure 7 Manner of assembling/pulling out the blow in and suction

- 1 – Bottom surface
- 2 – Blow-in (DO NOT BLOCK the holes!!!)
- 3 – Suction (DO NOT BLOCK the holes!!!)

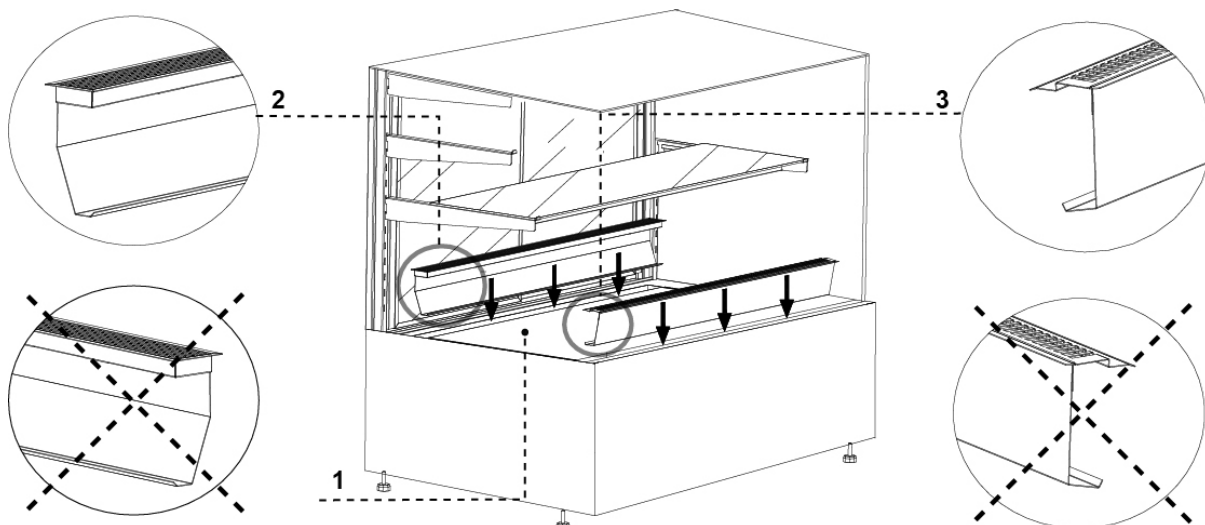

Do not use mechanical agents to quicken the defrosting process!

It is recommended to make a break in the operation **once a month** in order to clean the interior, naturally defrost the evaporator and clean the condenser, and evaluate the condition for door seal (CURP2)

Figure 8 Cleaning the condenser

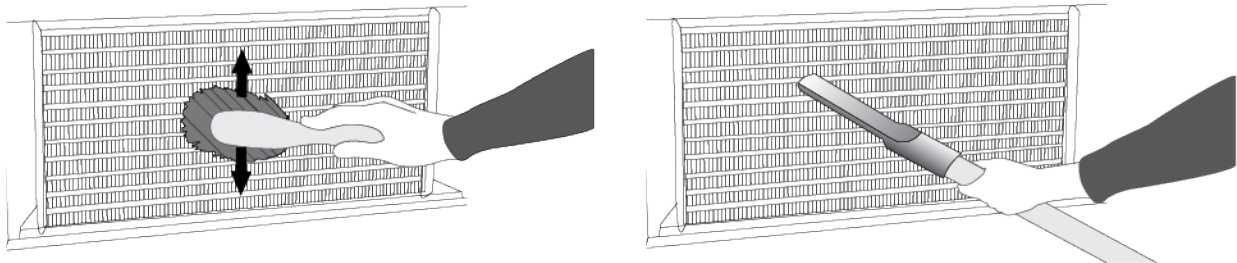

It is essential to keep the condenser of the device clean. Dirt may hinder the heat exchange, causing mainly an increase in electric energy consumption and may cause damage of the compressor. In order to clean the condenser it is necessary to unscrew the sheet metal screws and pull the wind brace out of catch by lifting it up. Clean condenser lamellas with help of soft brush or paint brush. If the condenser is extremely dirty (blocking of lamellas) it is indicated to use vacuum cleaner or compressed nitrogen to suck / blow the dirt from between lamellas.

The seller shall not be held responsible for any condenser damages in the case of non-observance of condenser cleaning instructions

*(This concerns CURP2, CURLP2, and CURHP2) Door seal should be cleaned solely with clean water without any cleansing agents and it should be thoroughly dried. **The seal cannot get into contact with oily substances or grease! Ensure door closed properly during maintenance procedures.***

Test: place a sheet of paper between the seal and the casing and close the door. The paper should pose a tangible resistance during an attempt to pull it out.

Elements of equipment can corrode as result of improper use and maintenance. To prevent damage: Do not allow contact of the with substances containing chlorine and/ or baking soda in different varieties, which destroy the protective layer and components of the equipment (also includes various stainless steel)

6. SERVICE

6.1. Faults identification and repair

In case of any difficulties during actuation of the equipment or during its operation, please return to the chapters in this manual, which explain the performed operation. This aims to ensure the equipment is properly operated. If you still experience difficulties, the following will help you solve the problems.

The equipment is not working... – Make sure that:

- The equipment is connected to the power supply.
- Voltage and frequency are compliant with those recommended by the manufacturer, 115V/60Hz.
- The main switch is turned on.
- Thermostat is turned on.

The equipment is operating, but the light is off... – Make sure that:

- Light switch is turned on.
- Lamp or starting switch of the equipment are not burnt.

Water leakage from under the device

- Check whether the equipment is properly levelled.
- Empty the condensate container.

The equipment does not reach the proper temperature, the light is on... – Make sure that:

- The main switch is on.
- Temperature setting on the thermostat is properly set.
- Thermostat works properly.
- The condenser is clean, if necessary – clean the condenser.
- Ambient temperature does not exceed 25°C.
- Enough time has passed for products to be cooled.
- Ventilation holes are not blocked.
- Relative air humidity no more than 55%.

Thermostat displays E0 or E1 or L0 or HI or EE or Ed or DF instead of temperature:

- E0 – failure of temperature sensor inside the chamber – call authorized service.
- L0 – low temperature alarm (lower than temperature range set within the equipment – call authorized service.
- HI – high temperature alarm – call authorized service.
- EE – internal defect of the regulator – call authorized service.
- Ed – maximum defrosting time exceeded.
- DF – defrosting in progress (this is not an alarm signal).

The equipment is working too loud... – Make sure that:

- The equipment is standing stably and properly levelled.
- Furniture adjoining the equipment does not vibrate when self-contained compressor is working.

Noises made by the operating device is normal. The units are equipped with ventilators, engines and compressors, which turn on and off automatically. Each compressor makes certain noises when operating. These sounds are made by the aggregate engine and by cooling agent flowing through the circuit. This phenomenon constitutes a technical feature of cooling devices and does not signify equipment failure.

Steam precipitation on glasses is normal in the event of high relative air humidity exceeding 55% and does not require calling for service.

6.2 Service

IGLOO Refrigeration service

Telephone number: 416-663-3051 or (toll free) 1-888-408-8819

E-mail: service@igloo400.com

If after checking points described in chapter 6.1 “Faults identification and repair” and the equipment still does not work properly,

Please contact Technical Service @ IGLOO Refrigeration.